

Operating Instructions

DV NTSC

Digital Video Camera Recorder

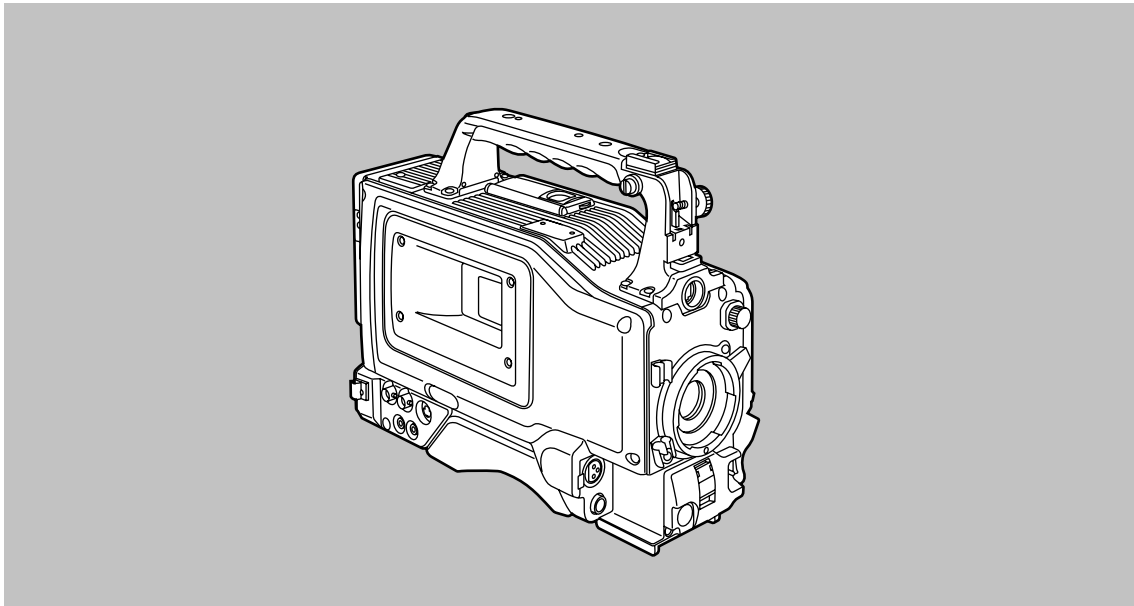

AG-DVC200P





Panasonic[®]

Before attempting to connect, operate or adjust this product, please read these instructions completely.

* This camera recorder is designed to be used exclusively with the standard size of DV tapes. Do not use DVCPRO tapes or other sizes of tapes.

	CAUTION RISK OF ELECTRIC SHOCK DO NOT OPEN	
CAUTION: TO REDUCE THE RISK OF ELECTRIC SHOCK, DO NOT REMOVE COVER (OR BACK). NO USER SERVICEABLE PARTS INSIDE. REFER TO SERVICING TO QUALIFIED SERVICE PERSONNEL.		

 The lightning flash with arrowhead symbol, within an equilateral triangle, is intended to alert the user to the presence of uninsulated “dangerous voltage” within the product’s enclosure that may be of sufficient magnitude to constitute a risk of electric shock to persons.

 The exclamation point within an equilateral triangle is intended to alert the user to the presence of important operating and maintenance (service) instructions in the literature accompanying the appliance.

WARNING:
TO REDUCE THE RISK OF FIRE OR SHOCK HAZARD, DO NOT EXPOSE THIS EQUIPMENT TO RAIN OR MOISTURE.

CAUTION:
TO REDUCE THE RISK OF FIRE OR SHOCK HAZARD AND ANNOYING INTERFERENCE, USE THE RECOMMENDED ACCESSORIES ONLY.

CAUTION:
TO REDUCE THE RISK OF FIRE OR SHOCK HAZARD, REFER CHANGE OF SWITCH SETTING INSIDE THE UNIT TO QUALIFIED SERVICE PERSONNEL.

FCC Note:
This device complies with Part 15 of the FCC Rules. To assure continued compliance follow the attached installation instructions and do not make any unauthorized modifications.

This equipment has been tested and found to comply with the limits for a class A digital device, pursuant to Part 15 of the FCC Rules. These limits are designed to provide reasonable protection against harmful interference when the equipment is operated in a commercial environment. This equipment generates, uses, and can radiate radio frequency energy and, if not installed and used in accordance with the instruction manual, may cause harmful interference to radio communications. Operation of this equipment in a residential area is likely to cause harmful interference in which case the user will be required to correct the interference at his own expense.

Replace battery with part No. CR2032 only. Use of another battery may present a risk of fire or explosion. Caution—Battery may explode if mistreated. Do not recharge, disassemble or dispose of in fire.



ATTENTION:
The product you have purchased is powered by a nickel cadmium battery which is recyclable. At the end of its useful life, under various state and local laws, it is illegal to dispose of this battery into your municipal waste stream. Please call 1-800-8-BATTERY for information on how to recycle this battery.

 indicates safety information.

CONTENTS

Introduction	4	Normal recording	26
Features	4	Recording methods	26
Features of camera unit	4	Scene-to-scene continuity	26
Features of VTR unit	4	Audio recording	27
System configuration	5	Selecting the audio input signals	27
Parts and their functions	6	Adjusting the recording level	27
Preparations	10	Monitoring the sound during recording	27
Using the AU-BP402 or AJ-BP490 battery pack made by Panasonic	10	Playback (checking what has been recorded)	28
Using a battery pack made by Anton Bauer	11	Rec review	28
Using the NP-1B battery pack made by Sony	11	Other functions	28
Using an AC power supply (with the AJ-B75 AC adapter)	12	Still-picture playback	28
Attaching the lens	12	INTERVAL REC (intermittent recording) function	28
Mounting the unit on a tripod	13	Variable speed (FF/REW) playback	28
Detaching the unit from the tripod attachment	13	INDEX SEARCH mode	28
Attaching the viewfinder and microphone	13	Using the unit with external components	29
Attaching the shoulder belt	13	Connection to a video component with DV connector	29
Setting the camera ID	14	Connection to a PC capable of non-linear editing	29
Setting the date and time	14	Menu operations	30
Lens adjustments and checks	15	Menu display enable/disable	30
Flange back adjustment	15	Displaying sub-menus and deciding on settings	30
White shading check	15	Setting menu configuration	31
White shading adjustment	15	Menu contents	32
Viewfinder displays	16	SCENE menu (main menu)	32
Viewfinder lamp displays	16	MAIN menu 1 of 2 (main menu)	33
Viewfinder screen status displays	16	MAIN menu 2 of 2 (main menu)	35
Selecting the viewfinder screen display	19	Warning system	39
White balance and black balance adjustment	20	Emergency eject	39
Automatic white balance adjustment	20	Maintenance	40
Automatic black balance adjustment	20	Condensation	40
Electronic shutter settings	21	Replacing the backup battery	40
Concerning the shutter modes	21	Cleaning the heads	40
Setting the shutter mode and speed	21	Cleaning inside the viewfinder	40
Setting the synchro scanning mode	21	Concerning phenomena inherent to CCD cameras	40
Time data settings	22	Error codes	40
Setting the user's bit	22	Specifications	41
Setting the time code	22		
Scene files	23		
Scene file function	23		
Scene file setting method	23		
Editing scene filenames (USER files)	23		
Returning a scene filename to its default	24		
How to use file select	24		
List of scene file settings	25		
List of file settings	25		

Introduction

This is the first DV format integrated camera VTR that supports standard cassettes. It combines the digital camera technology fostered by broadcast equipment with the dependability of the DVCPRO mechanism. It has a compact size, light weight and low-

power consumption, and it is capable of recording for many hours. Both its camera unit and VTR unit incorporate digital signal processing to achieve even greater improvements in picture quality and stability.

Features

Features of camera unit

● 1/2 type IT 3-CCD configuration

The camera's high resolution of about 800 lines and its minimum subject brightness of 0.5 lux make easy work of shooting under low lighting conditions, and they achieve bright camera images with a high sensitivity.

● Digital processing incorporated

Full-blown digital processing circuitry fostered by broadcasting applications is featured to ensure a high performance, sophisticated functions and a high level of dependability.

● Replacement lens system

The bayonet system is employed to enable 1/2 lenses made by Fujinon or Canon to be mounted for use.

● CC/ND filter with a 4-leaf configuration adopted as a standard accessory

This configuration enables the optimum filter for the subject brightness and color temperature to be selected.

● Shooting support functions

Scene file dial

This makes it easy to select six scene file settings to suit the prevailing shooting conditions.

ATW (auto tracking white) function

The auto tracking white function comes in handy when shooting successive scenes with different light sources.

Quick focus function

This automatically controls the iris and shutter to provide support for ensuring easy focusing.

Full auto function

This is useful for emergency shooting when, for instance, there is not enough time to perform the camera settings.

Auto iris mode selection function

This enables three auto iris settings to be selected. The settings can easily be switched to match the shooting conditions.

Menu jog dial system

A jog dial button enabling easy menu settings is provided on the front panel of the camera.

Features of VTR unit

● DV format

The VTR unit compresses the images using a component digital recording system that incorporates the latest compression technology. For recording the sound, the unit uses non-compression PCM recording which achieves an excellent signal-to-noise ratio, frequency band, waveform characteristics and reproducibility of the finely detailed parts. Both picture quality and sound quality are taken to new heights by this format.

● Standard tape drive

The DVCPRO mechanism with its proven track recorded in broadcasting applications has been put to use to ensure the same high level of dependability while at the same time enabling long recordings lasting up to a maximum of 270 minutes.

● High system capabilities

The unit comes with DV connectors as a standard accessory. These enable hookup with other DV components and DV non-linear devices.

The battery packs made by Anton Bauer and battery systems made by other companies are all supported.

● Other features

Frame-to-frame continuity

Simply by pressing the VTR START button or VTR button on the lens, the continuity from one frame to the next is assured with a precision of 0 to +1 frame or less.

Rec review function

This automatically rewinds the tape for the last 2 to 10 seconds recorded and plays back the recording. This enables what was recorded to be monitored without delay.

Built-in time code generator/reader

This enables the time code information to be recorded on the dedicated sub-code track and played back.

Time stamp function

This superimposes the date and time onto the camera's images and records them.

Interval rec function

This function enables simply interval shooting. It is particularly effective for shooting programs on nature or art.

System configuration

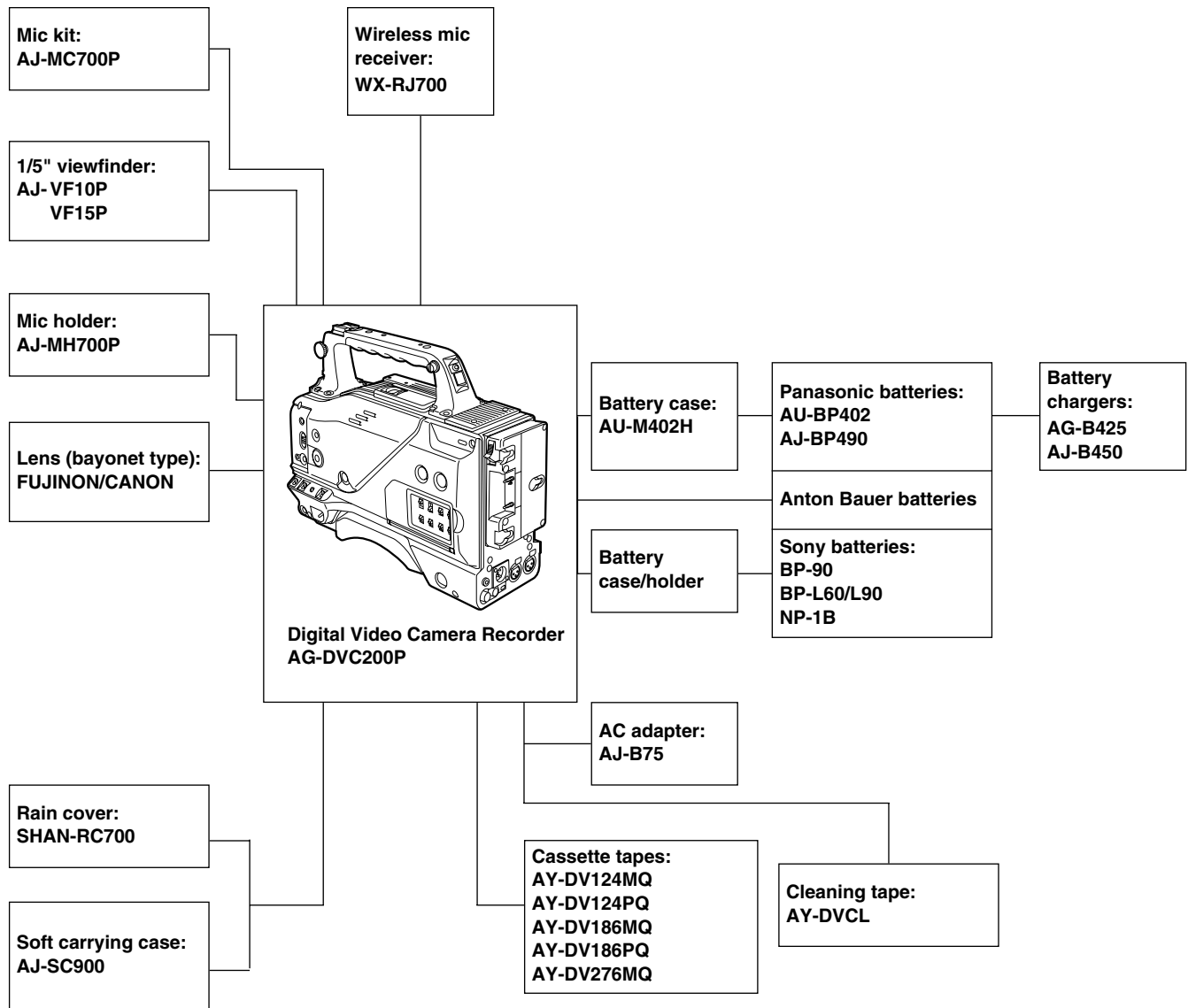

<Note> Checking the lens shading compensation

This unit comes with a function which provides shading compensation for the lens. Check that the compensation is optimum for the type of lens used. For further details, refer to "Lens adjustments and checks" (page 15).

Lens shading compensation data selection

Lens classification	A	B	C	USER
Lens type	S18 x 6.7BERM4 S18 x 6.7BRM4 S19 x 6.5BERM4 S19 x 6.5B YH18 x 6.7IRS YH12 x 4.8IRS	YH18 x 6.7KRS YH14 x 7.3KRS YH12 x 4.8KRS S14 x 7.5BRM4 S17 x 6.6BRM4	S14 x 7.3BRM (For AG-DVC200D)	Lens other than A, B or C

Parts and their functions

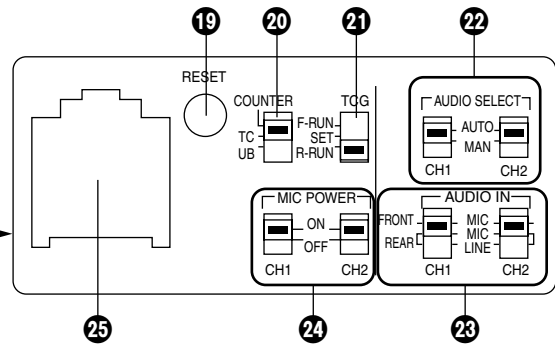
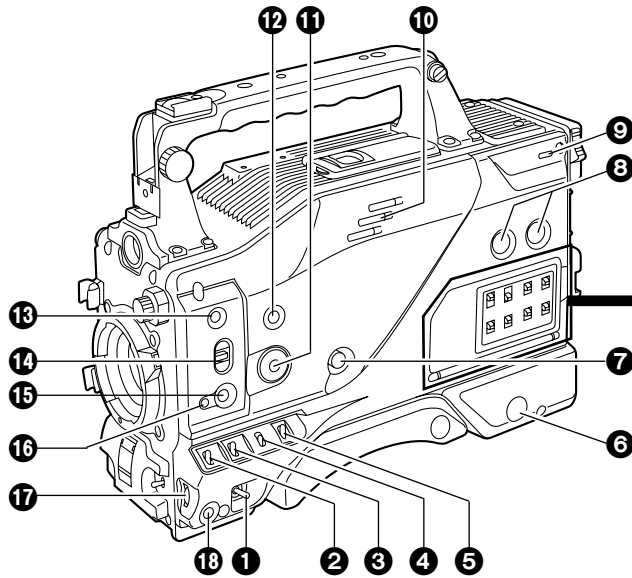

1 POWER switch

This switch turns the power ON and OFF.

2 VTR STBY/SAVE (tape protection) switch

This switches the power supply mode when the VTR is set to the rec pause mode in which recording is temporarily suspended.

STBY: In this mode, recording starts immediately by pressing the VTR START button.

SAVE: This is the tape protection mode. The tape drum is stopped in the half-loading status. Less power is consumed at this position than at the STBY position so that the battery will supply power to the unit for a longer period of time.

Compared with the STBY position, more time is taken to start recording after the VTR START button is pressed. When the switch is set to the SAVE position, the VTR SAVE lamp inside the viewfinder lights up.

<Note>

When the PAUSE TIMER time (initial setting: 10 minutes) has elapsed in the STBY mode, the unit is automatically set to the SAVE mode. For further details, refer to the table for <VTR OPTION> in the section on the sub-menu screens (page 34).

3 GAIN selector switch

When the camera screen is dark, turn this switch to a position which will increase the gain and brighten the screen.

The gain for each item can be selected on-screen. For further details, refer to the table for <SW MODE> in the section on the setting menu screens (page 33).

L: The switch is normally set to this position. The gain at this position was set to 0 dB at the factory prior to shipment.

M: The gain of the camera's video amplifier is increased. The gain at this position was set to 9 dB at the factory prior to shipment.

H: The gain of the camera's video amplifier is increased even more. The gain at this position was set to 18 dB at the factory prior to shipment.

4 OUTPUT/AUTO KNEE selector switch

This switch selects the video signals which are to be output from the camera unit to the VTR unit, viewfinder and/or video monitor.

CAM, AUTO KNEE ON:

The images shot by the camera are output. The AUTO KNEE circuit operates.

CAM, AUTO KNEE OFF:

The images shot by the camera are output. The MANUAL KNEE circuit operates.

BARS:

Color bar signals are output. The AUTO KNEE circuit does not operate.

AUTO KNEE function

When shooting with the level set to people or scenes against a high-brightness background, the background will be whitened out, and the buildings and scene in the background will be blurred. If the AUTO KNEE function is activated at times like this, the background will be reproduced clearly. This function is effective for shooting in the following situations:

- When shooting people in the shade under a clear sky
- When simultaneously shooting people in a car or indoors and the outside scenery through a window
- When shooting scenes with a strong contrast

5 WHITE BAL (white balance memory selector) switch

A or B: When the AUTO W/B (white/black) BAL switch on the front panel is operated to adjust the automatic white balance, the adjusted value is automatically stored in A or B.

PRST: The color temperature is set to 3200K in the preset mode. The AUTO W/B BAL switch does not work at this position.

<Reference>

The automatic tracking white balance mode (ATW) can be set to A, B or PRST. For further details, refer to the table for <SW MODE> in the section on the sub-menu screens (page 33).

Parts and their functions

⑥ BREAKER switch

If an excessively high current flows inside the unit due to some trouble or other, the circuit breaker is tripped and the power is automatically turned off to protect the unit.
Push this button in after conducting an inspection or repairs inside the unit. If there is no trouble, the power will come back on.

⑦ MONITOR (volume) control

This is used to adjust the volume of the monitor speaker or earphone.

⑧ AUDIO LEVEL CH1, CH2 (audio channel 1, 2 recording level) controls

These are used to adjust the CH1 and CH2 recording levels while monitoring the level meter inside the viewfinder.

⑨ POWER/WARNING lamp

This lamp lights up green when the power is turned on, and it flashes in green during interval recording. When a warning is given, it lights up red or flashes in red to alert the user to trouble. For further details, refer to "Warning system" (page 38).

⑩ SPEAKER

The sound can be monitored through this speaker.
When an earphone is connected to the PHONE jack, the sound of the speaker will be automatically cut off.
What can be monitored is the mixed sound of CH1 and CH2.

⑪ SCENE FILE dial

This enables the camera settings that match the shooting conditions to be selected. For further details, refer to "How to use scene files" (page 24).

⑫ MODE CHECK button

This enables the setting modes of the camera's control switches to be checked in the viewfinder.

⑬ QUICK FOCUS button

This supports the focusing of the subject. When it is pressed, the lens iris is opened for about 10 seconds. It makes the depth of field shallower and facilitates focusing.

⑭ AUTO IRIS MODE selector switch

This is used to select the position that matches the shooting conditions when shooting by automatically adjusting the lens iris.

BACK.L: When making a back-lit subject brighter for shooting

STD: For normal shooting

SPOT.L: For shooting a spot-lit subject

⑮ FULL AUTO button

This is pressed when there is no time to check the camera unit's settings. The lens iris and white balance will be automatically adjusted.

⑯ FULL AUTO lamp

This lights up when FULL AUTO shooting has been performed.

⑰ JOG dial button

This is used to select the menu items and perform settings when the MENU button ⑱ is at the ON position. When the synchro scanning mode has been selected for the shutter speed, the shutter speed can be easily adjusted more finely.

⑱ MENU button

This is used to switch the menu ON and OFF.

⑲ RESET button

This is used to reset the numerical value of the counter or time code.

<Note>

This value is reset immediately when the COUNTER has been selected. When TC or UB has been selected, the reset button works only when the TCG selector switch is at the SET position.

⑳ COUNTER selector switch

This is used to switch the counter display.

COUNTER: A relative numerical value is displayed by the counter. However, when the tape recording includes discontinuous parts, the counter reading may also lack continuity.

TC: The time code is displayed.

UB: The user's bit is displayed.

㉑ TCG selector switch

This sets the time code operation mode to FREE RUN, REC RUN or SET. For further details, refer to "Setting the time data" (page 22).

㉒ AUDIO SELECT CH1, CH2 (audio channel 1, 2 auto/manual level adjustment selector) switches

These are used to select the method used to adjust the audio levels of audio channels 1 and 2.

AUTO: The audio level is adjusted automatically.

MAN: The audio level is adjusted manually.

㉓ AUDIO IN (audio input selector) switches

These are used to select the input signals to be recorded on CH1 and CH2.

FRONT : The input signals from the microphone connected to (MIC) the MIC IN connector are recorded.

REAR : The input signals from the microphone connected to (MIC) the AUDIO IN CH1/CH2 connector are recorded.

REAR : The input signals from the line connected to the (LINE) AUDIO IN CH1/CH2 connector are recorded.

㉔ Mic power switches

These are used to turn ON and OFF the phantom power (+48V) for each rear jack channel.

<Note>

ON or OFF can be set for supplying the phantom power of the front microphone using "FRONT MIC POWER" on the <MIC/AUDIO> sub-menu screen.

㉕ Backup battery compartment

For further details on replacing the backup battery, refer to "Replacing the backup battery" (page 40).

Parts and their functions

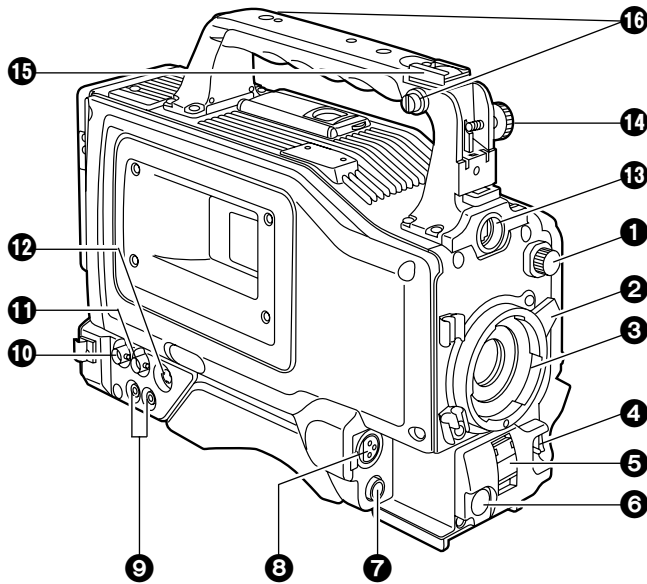

① CC/ND filter selector knob

This is used to select the filter to match the subject brightness.

- 1 : 3200K
- 2 : 5600K+1/8ND
- 3 : 5600K
- 4 : 5600K+1/64ND

② Lens lever

This lever is tightened to secure the lens after the lens has been attached to the lens mount.

③ Lens mount (bayonet type)

The lens is attached to this mount.

④ AUTO W/B (white/black) BAL switch

AWB: The white balance is automatically adjusted. When the AWB memory selector switch on the side panel is set to A or B and then the AUTO W/B BAL switch is operated, the adjustment value is recorded in the memory. Bear in mind that the switch does not work when it is set to the ATW or PRST position.

ABB: The black balance is automatically adjusted.

⑤ SHUTTER switch

This is the ON/OFF selector switch of the electronic shutter.

OFF : The electronic shutter does not operate.

ON : The electronic shutter operates.

SEL : This is used when the electronic shutter speed is to be changed. The switch is a non-locking type. The shutter speed changes each time it is operated. For further details, refer to "Electronic shutter settings" (page 25).

⑥ VTR START/STOP button

This starts or stops the video recording.

⑦ LENS jack (12-pin)

The connecting cord of the lens is connected to this jack. For further details on the lenses that can be used, refer to the operating instructions of the lenses concerned.

⑧ MIC IN (mic input) jack (XLR, 3-pin)

The accessory microphone is connected to this jack. The power for the microphone is supplied from this jack.

⑨ AUDIO OUT jacks (pin jacks)

An audio component is connected to these jacks. The sound for channel 1 and channel 2 is output separately.

⑩ GENLOCK IN connector (BNC)

Supply the sync signal (black burst signal) to this connector when gen-locking the camera pictures (CAM OUT jack) of the unit.

⑪ CAM OUT jack

This is the dedicated output jack for the camera's pictures.

⑫ S-VIDEO OUT jack (Y/C jack)

When pictures are to be recorded with a backup VTR connected to the S-VIDEO OUT jack, bear in mind that the unit's playback pictures will be recorded onto the backup VTR if any operation (such as REC CHECK) that performs VTR playback is executed.

⑬ Viewfinder connector

The viewfinder plug is connected to this connector.

⑭ Viewfinder stopper screw

This screw is used to secure the viewfinder.

⑮ Light shoe

The video light or other such device is attached here.

⑯ Shoulder belt fittings

The shoulder belt (optional accessory) is attached here.

Parts and their functions

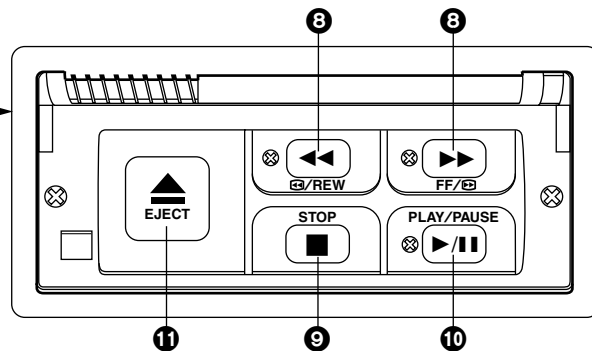
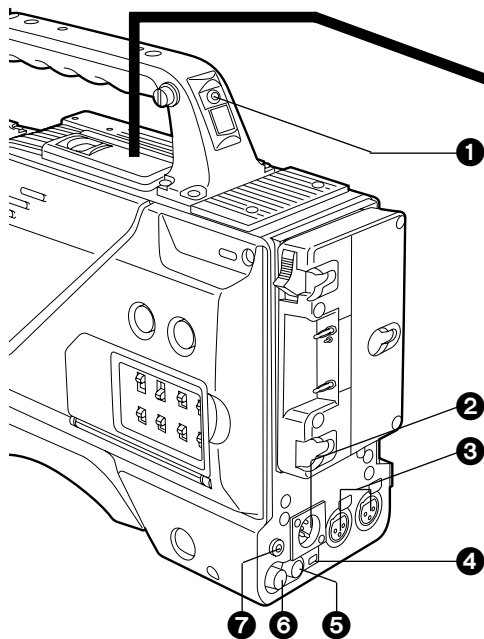

① TALLY lamp

This lights up when the unit is set to the recording mode. It flashes when it is being transferred to the recording mode.

② External DC input socket

This is the input socket of the external power supply (DC power supply). When an AC adapter is connected here, power is automatically supplied from the external source.

③ AUDIO IN CH1, CH2 (audio input channel 1, 2) jacks (XLR, 3-pin)

An external microphone or line input signals are connected to these jacks.

④ DV I/F connector (complying with IEEE 1394 standard)

A digital video component or computer equipped with a DV connector is connected to this connector using a DV cable (optional accessory). For further details, refer to "Using the unit with external components" (page 29).

⑤ DC OUT (DC power supply) output socket

This normally serves as the DC 12V output socket. A current of approximately 1A can be taken out.

When the HDD adapter scheduled to be developed in the future is connected here, it will be possible to supply a 7V voltage.

⑥ VIDEO OUT jack (BNC)

This is the composite video jack for a monitor.

<Note>

When pictures are to be recorded with a backup VTR connected to the VIDEO OUT jack, bear in mind that the unit's playback pictures will be recorded onto the backup VTR if any operation (such as REC CHECK) that performs VTR playback is executed. Use the exclusive camera output jack for backup recording.

⑦ PHONES (earphones) jack (mini jack)

The earphones (stereo) for monitoring sound are plugged in here. When the earphones are connected, no sound will be output from the speaker.

⑧ REW (rewind)/FF (fast forward) buttons/lamps

- When one of these buttons is pressed in the stop mode, the high-speed playback (rewind or fast forward) mode is established, and the corresponding lamp lights.

- When one of these button is pressed in the playback mode, the 4X speed playback (rewind or fast forward) mode is established, and when the same button is pressed again, the 8X speed playback (rewind or fast forward) mode is established.

Each time the button is then pressed, the mode is switched between 4X speed playback and 8X speed playback.

- When one of these buttons is pressed in the STILL or REC PAUSE mode, the 1× speed playback (rewind or fast forward) is established while the button is held down. When the button is released, the unit returns to the previous mode (STILL or REC PAUSE).

The variable speed playback mode is released by pressing the STOP button, PLAY/PAUSE button or EJECT button.

⑨ STOP (stop) button

The tape stops traveling when this button is pressed. However, the button cannot be operated during recording. To stop recording, first set the unit to the REC/PAUSE mode, and then press the STOP button.

⑩ PLAY (playback)/PAUSE button/lamp

Playback commences when this button is pressed, and the lamp lights. When it is pressed again, the STILL (stop) mode is established, and the lamp flashes.

When it is pressed once more, the playback mode is restored.

⑪ EJECT (eject) button

When this button is pressed, the cassette holder rises, and the cassette tape can be inserted or removed. This button cannot be operated while the unit is recording, in which case first set the unit to the REC/PAUSE mode, and then press the EJECT button.

Preparations

Using the AU-BP402 or AJ-BP490 battery pack made by Panasonic

Recharge the battery pack using the battery charger specifically designed for each individual battery pack. For the charging time and other details, refer to the operating instructions of the battery charger used.

1 Remove the battery holder.

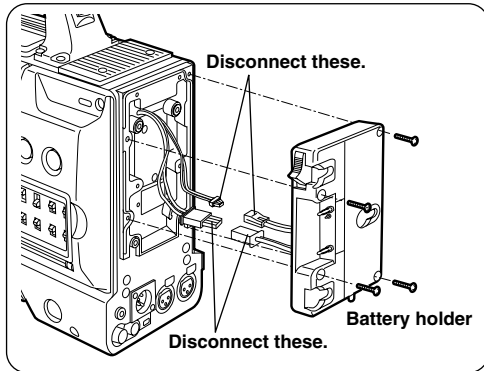

2 Install the battery case into the unit.

- ① Connect the unit's cable with the cable of the AU-M402H battery case.
- ② Use a screwdriver to install the AU-M402H battery case into the unit.

The holes for tightening the screws can be seen when the cover is opened and the rubber caps are raised. Use a screwdriver to tighten the screws, and install the battery case into the unit. Ensure that the screws are tightened up as far as they will go.

<Note>

- Do not pull the rubber caps with great force.
- Be careful not to catch up the cables when installing the battery case.

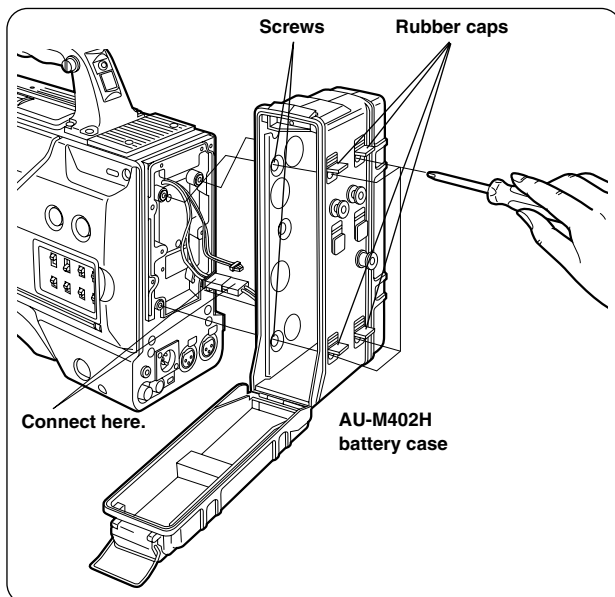

3 Connect the plug of the battery pack to the connector inside the battery case, and insert the battery pack into the case.

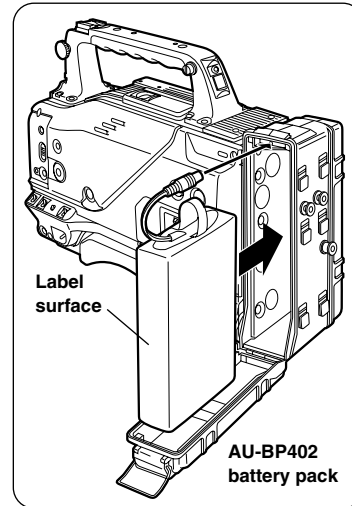

<Note>

The power must be turned off without fail before connecting or disconnecting the plugs.

4 Set the battery type.

Select the battery type using <BATTERY> on the sub-menu screen.

Select "TYPE A" if the AJ-BP490 is to be used; select "NiCd12" if the AU-BP402 is to be used. (See page 34)

Preparations

Using a battery pack made by Anton Bauer

Before use, charge the battery pack using the exclusive battery charger made by Anton Bauer.

For the charging time and other details, refer to the operating instructions of the battery charger used.

1 Attach the battery pack made by Anton Bauer.

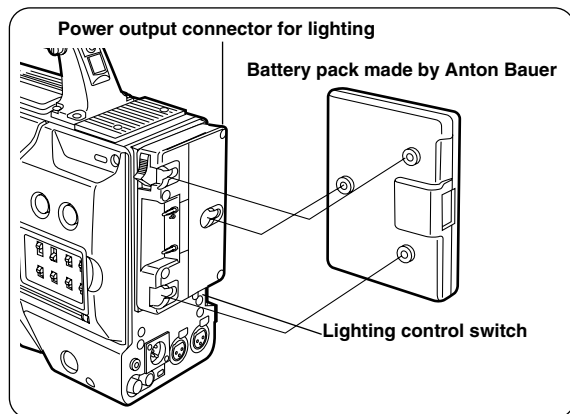

<Reference>

A battery holder made by Anton Bauer is equipped with a power output connector for the lighting and a lighting control switch to enable a light to be easily attached. For details on the lighting systems available, contact Anton Bauer.

2 Insert the battery pack and slide it in the direction of the arrow.

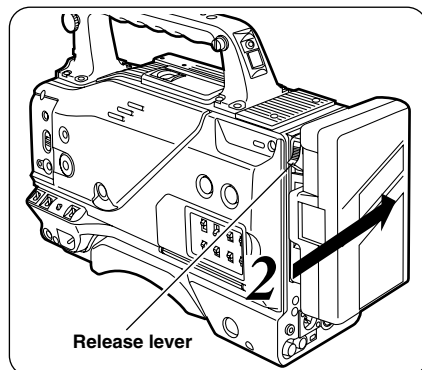

<Reference>

To remove the battery pack, slide it in the opposite direction to the one in which it was attached while keeping the release lever on the battery holder pulled down all the way.

3 Set the battery type.

Select the battery type using <BATTERY> on the sub-menu screen.

Example: Select "NiCd13" if the TRIMPAC13 is to be used; select "NiCd14" if the TRIMPAC14 is to be used. (See page 34)

Using the NP-1B battery pack made by Sony

Before use, charge the battery pack using the exclusive battery charger made by Sony.

For the charging time and other details, refer to the operating instructions of the battery charger used.

1 Remove the battery holder.

Refer to step 1 on page 14.

2 Attach the battery made by Sony to the unit.

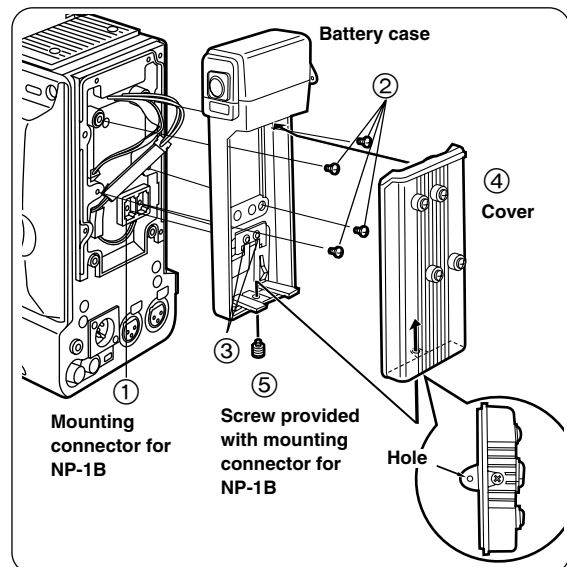

First, remove the battery holder cover.

- ① Attach the mounting connector for the NP-1B.
- ② Use the mounting screws to mount the battery case.
- ③ Tighten the screw for the power supply contact.
- ④ Insert the top of the cover in the direction of the arrow.
- ⑤ Align the hole in the bottom of the cover (metal part) with the hole in the bottom of the battery case, and attach using the screw provided with mounting connector for NP-1B.

3 Set the battery type.

Select the battery type using <BATTERY> on the sub-menu screen.

Select "NiCd12" if the NP-1B is to be used. (See page 34)

Preparations

Using an AC power supply (with the AJ-B75 AC adapter)

- 1 Connect the unit's external DC input socket with the DC OUT socket on the AJ-B75 AC adapter.

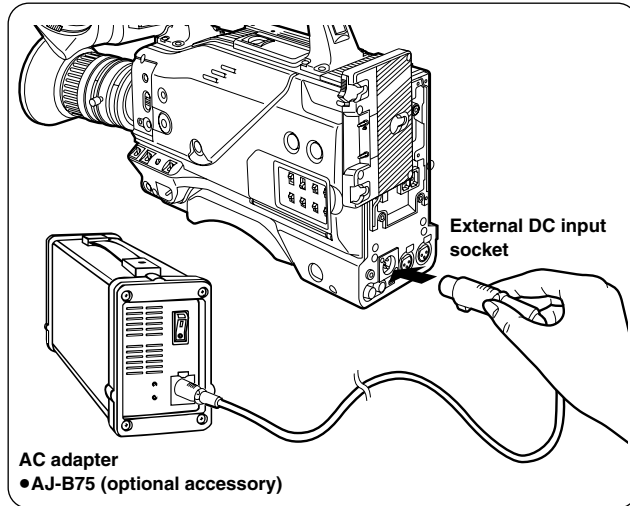

- 2 Turn on the AC adapter's power.

- 3 Set the unit's POWER switch to ON.

When an AC adapter other than the AJ-B75 is to be used, check the pin signals of the external DC input socket.

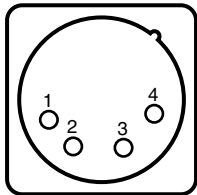

External DC input socket

Pin No	Signal
1	GND
2, 3	-
4	+12V

<Notes>

- When both a battery pack and an AC adapter have been connected, the power supplied from the AC adapter takes priority. It is also possible to attach/remove a battery while the AC adapter is being used.
- When an AC adapter is to be used, the unit's POWER switch must be set to ON only after the AC adapter's power has been turned on. If the power is switched on in the reverse sequence, the AC adapter's output voltage will rise slowly, possibly causing the unit to malfunction.

Attaching the lens

- 1 Raise the lens lever, and remove the mount cap.

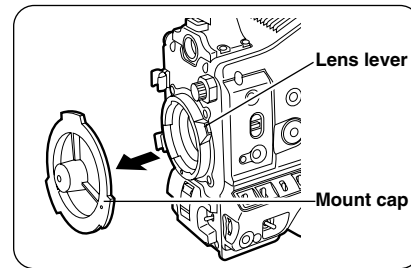

- 2 Fit the center mark on the lens into the center cutout on the top of the lens mount, and attach the lens.

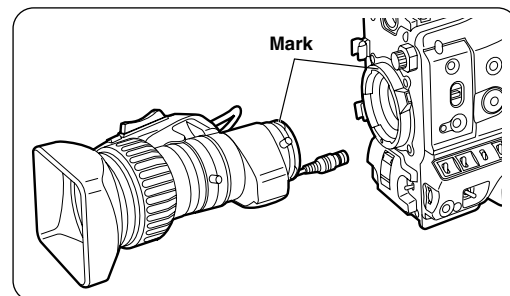

- 3 Pull down the lens lever to secure the lens.

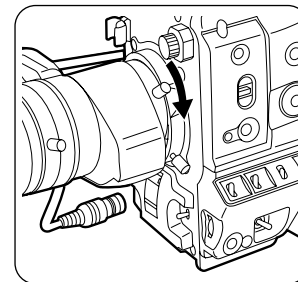

- 4 Push the cable into the cable clamp, and connect it to the LENS jack.

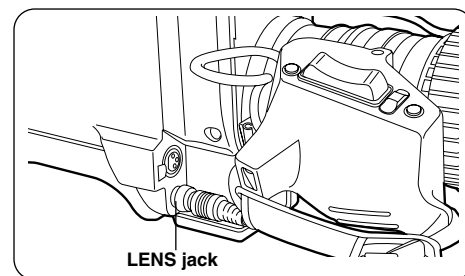

- 5 Proceed with the flange back adjustment for the lens.

<Notes>

- For details on how to handle the lens, refer to the operating instructions of the lens.
- While the lens is removed, attach the mount cap to protect the unit.

Preparations

Mounting the unit on a tripod

Use the tripod attachment to mount the unit on a tripod.

1 Mount the tripod attachment on the tripod.

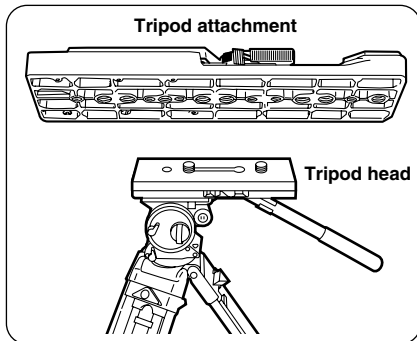

<Note>

Take account of the center of gravity of the unit and that of the tripod attachment when selecting the attachment hole. Check that the diameter of the hole selected matches the diameter of the tripod head screw.

2 Mount the unit on the tripod attachment.

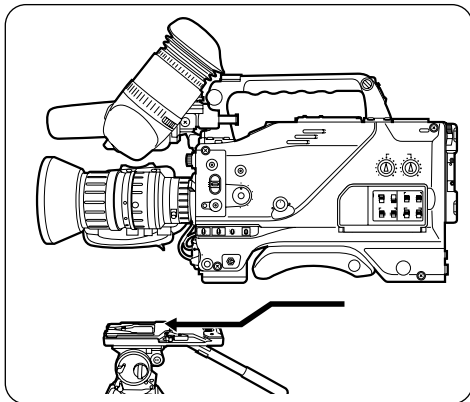

Slide the unit along the groove toward the front until it clicks into place.

Detaching the unit from the tripod attachment

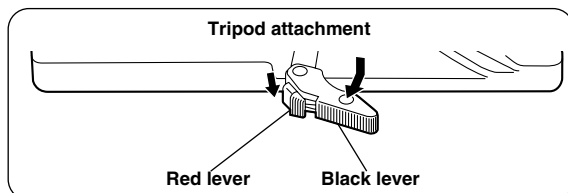

While pushing down the red lever, move the black lever in the direction of the arrow and slide the unit toward the back to remove it.

<Note>

If the pin of the tripod attachment fails to return to its original position after the unit has been detached, again move the black lever in the direction of the arrow while pushing down the red lever, and return the pin to its original position. Bear in mind that the unit cannot be attached if the pin remains in the center.

Attaching the viewfinder and microphone

For details on the attachment and adjustments of the viewfinder and microphone, refer to the operating instructions of the viewfinder.

Attaching the shoulder belt (optional accessory)

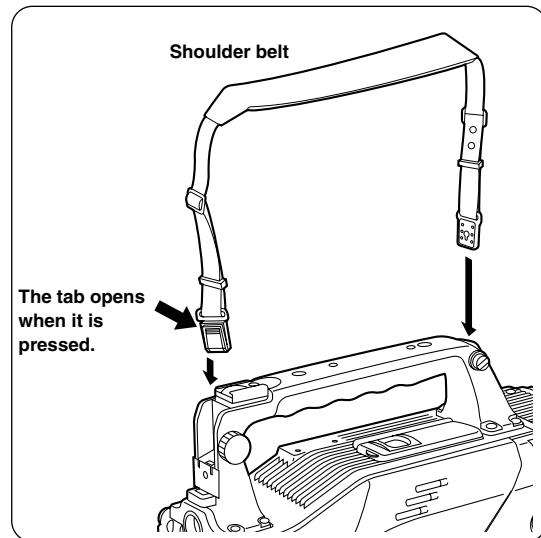

To disengage the shoulder belt, open the tabs of the attachment parts, and disengage.

The tab opens when it is pressed.



<Note>

Check that the shoulder belt is attached securely.

Preparations

Setting the camera ID

The camera ID is set on the <CAMERA ID> screen. Up to 12 alphanumeric, symbols and spaces can be used.

<Note>

The camera ID does not appear while the setting menu is displayed even when color bar signals are output.

- 1 Proceed with the sub-menu operation (page 30), and open the <CAMERA ID> screen.

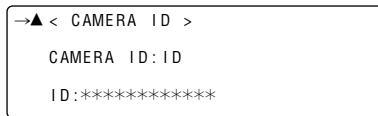

- 2 Turn the JOG dial button to move the arrow (cursor) to the ID item.

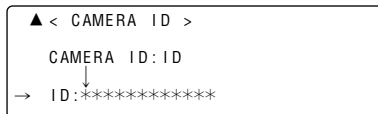

- 3 When the JOG dial button is pressed, the arrow (cursor) flashes to signal that the input mode has been established.

- 4 Keep turning the JOG dial button until the character to be set appears.

When the button is turned, the character display is switched in the following sequence:

Space:



Letters of the alphabet: A through Z



Numbers: 0 through 9



Symbols: ', >, <, /, -

- 5 Press the JOG dial button to enter the character.

- 6 Turn the JOG dial button to move the arrow (cursor) to the next position (on the right), and repeat steps 3, 4 and 5 to enter the remaining characters.

- 7 Press the MENU button to end the menu operation.

The setting menu is cleared, and the unit's current status is displayed.

To change the ↓ back to →, press the JOG dial button when the ↓ is above the colon (:).

<Note>

The camera ID input above will be recorded at the same time as the color bar signals.

Setting the date and time

- 1 Proceed with the sub-menu operation (page 34) to open the <TIME/DATE> screen.

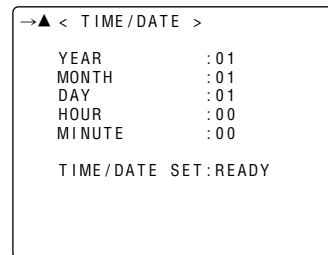

- 2 Turn the JOG dial button to select the item to be changed, and press the JOG dial button.

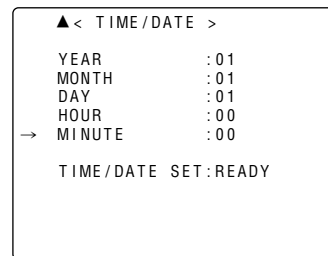

- 3 Turn the JOG dial button to change the setting, and then press the button to enter it.

- 4 When the setting is completed, turn the JOG dial button to select TIME/DATE SET, and press the button.

The READY display changes from ACTIVE to OK, and the clock function starts operating.

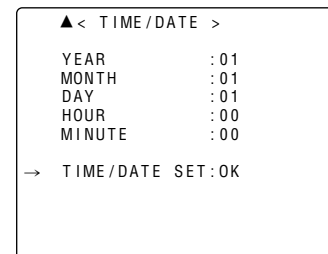

- 5 Press the MENU button to end the menu operation.

The setting menu is cleared, and the unit's current status is displayed.

<Note>

The seconds cannot be set. The time always starts from zero seconds.

Lens adjustments and checks

Flange back adjustment

The flange back (distance from the lens mounting surface to the image formation surface) is adjusted when a subject cannot be brought into focus precisely using either the telephoto or the wide angle positions when performing zoom operations.

Once the flange back has been adjusted, it need not be re-adjusted unless the lens is replaced. For details on the adjustment method and lens positions, refer to the operating instructions of the lens concerned.

White shading check

This unit enables the fixed data supporting three types of lens and the data supporting any desired adjustments to be used for white shading compensation. This data can be selected using LENS SHADING on the sub-menu (see page 35).

First, check that the type of lens used and the settings match. The fixed data settings are as follows:

Type A: Data for S18 x 6.7BERM4 (etc.) lenses.

Type B: Data for YH18 x 6.7KRS (etc.) lenses.

Type C: Data for S14 x 7.3BRM lens.

If the lens to be used does not correspond to any of these types, proceed to adjust the white shading described below by performing menu operations.

White shading adjustment

<Note>

Coloring may occur in the vertical direction near the open setting of the lens iris even when the white shading has been adjusted. This phenomenon is a characteristic inherent to lenses and optical systems, and it is not indicative of a failure.

1 Proceed with the camera settings for the adjustment.

- ① Mount the lens on the camera.
Do not forget to attach the lens cable.
- ② Set the electronic shutter to OFF and the gain to L (0 dB)
- ③ If the lens comes with an extender, disengage the extender function.
- ④ Proceed with the menu operation (page 30) to open the sub-menu <LENS SHADING> screen, and set "LENS SELECT" to USER.

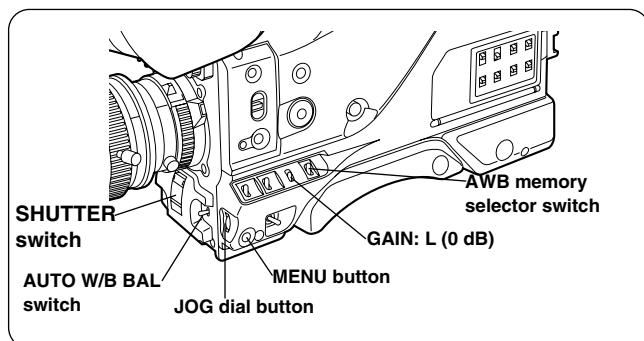

2 Proceed with the image settings.

- ① Shoot a piece of paper with no color unevenness.
- ② Set the lens iris to manual, and adjust it so that a zebra pattern fills the whole screen. Check that the lens iris is between f/4 and f/11.

<Notes>

- Flicker tends to occur under fluorescent lights, mercury lamps and other such lighting conditions. Use sunlight, halogen lamps or a light source which rarely give rises to flicker.
- If there is unevenness in the lighting, the zebra pattern will no longer appear on some parts of the screen. In a case like this, adjust the lighting position, etc.
- Adjust the lighting position, etc. also when the lens iris is not between f/4 and f/11.
- The electronic shutter must be left at the OFF setting.

3 Adjust the white balance and black balance.

- ① Set the WHITE BAL selector switch to A or B, and use the AUTO W/B BAL switch to execute the automatic white balance adjustment (AWB).
- ② Use the AUTO W/B BAL switch to execute the automatic black balance adjustment (ABB).
- ③ Once again, use the AUTO W/B BAL switch to execute the automatic white balance adjustment (AWB).

4 Repeat the operation in step 2-②.

5 Proceed with the white shading adjustment.

- ① Proceed with the menu operation (page 30), and open the sub-menu LENS SHADING screen.
- ② Turn the JOG dial button to align the cursor with LENS SELECT, and press the button. Then turn the JOG dial button further to align the cursor with USER, and press the button to select this item.
- ③ Use the JOG dial button to align the cursor with SHADING (USER), and select this item.
ACTIVE appears on the screen to indicate that the white shading is being automatically adjusted. The adjustment is completed when the ACTIVE display is cleared and OK appears.
- ④ Press the MENU button to close the menu screen.

6 If the lens comes with an extender, engage the extender function, and repeat steps 2 through 5.

Viewfinder displays

Viewfinder lamp displays

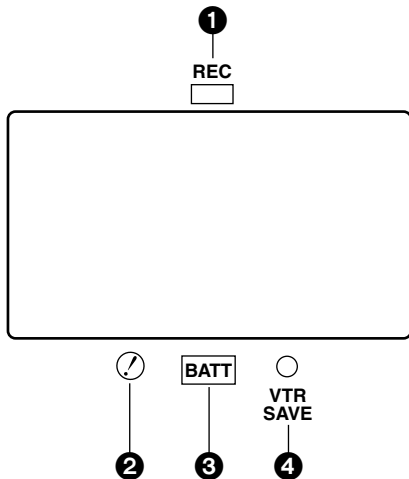

The displays shown in the example are those of the AJ-VF10. (For details on the viewfinder, refer to the operating instructions of the viewfinder available as an optional accessory.)

1 REC (record) lamp

This lights up red during recording. It flashes when an error has occurred. For further details, refer to "Warning system" (page 38).

2 (irregular operation status warning) lamp

This lights up when the unit is placed in an irregular operation status for any of the items set to ON in the sub-menu <!LED>. For details on selecting the items subject to the (irregular operation status warning) lamp display, refer to sub-menu <!LED> (see page 37).

3 BATT (battery) lamp

This starts flashing several minutes before the battery voltage drops to the level where the battery can no longer be used, and it remains lighted when the battery can no longer be used. To prevent an interruption to operation, replace the battery before the battery becomes completely discharged. For further details, refer to "Warning system" (page 38).

4 VTR SAVE (VTR power-saving) lamp

This lights up when the VTR SAVE/STBY switch is set to SAVE. It goes off during recording.

<Note>

After the period set for the pause timer is exceeded during Rec Pause, or after 1 minute has passed during Pause (Still), the unit will automatically switch to SAVE mode and the lamp will light, regardless of the VTR SAVE/STBY switch position.

Viewfinder screen status displays

In addition to the images, messages indicating the unit's settings and the operation mode appear on the viewfinder screen.

Also displayed are the center marker and safety zone markers.

At the top, bottom and right edges of the screen are the items which have been set to ON using the sub-menu <MARKER/ZEBRA>, <VF DISPLAY 1/2> and <VF DISPLAY 2/2> screens or the switches relating to the viewfinder displays. When a setting has been changed or an adjustment is made, a message informing the user of the setting details, adjustment transition status and adjustment result is displayed for about 3 seconds.

For further details, refer to the items concerned on the sub-menu <MARKER/ZEBRA>, <VF DISPLAY 1/2>, <VF DISPLAY 2/2>, <!LED>, <CAMERA ID> and <TIME DATE> screens.

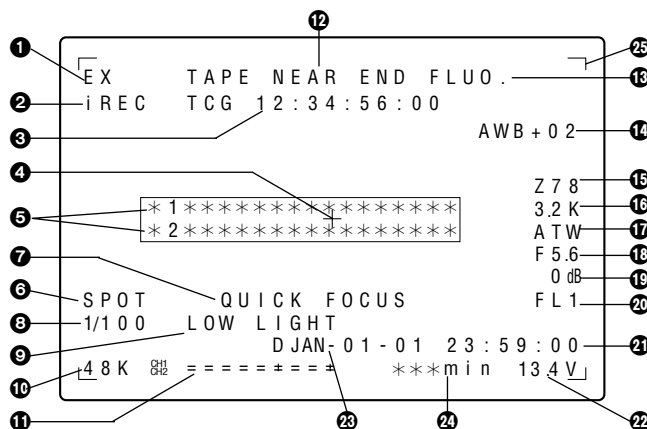

Status displays on viewfinder screen when MODE CHECK switch is ON (normal)

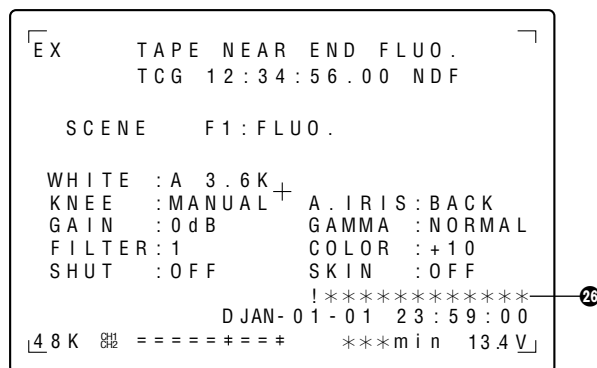

Status displays on viewfinder screen when MODE CHECK switch is ON (FULL AUTO)

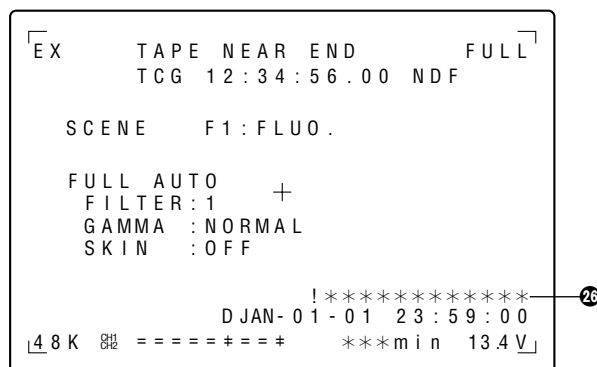

Viewfinder displays

Display item	What is displayed	Status causing the display to appear
① Extender display	EX	Displayed when the lens extender is being used.
② INTERVAL REC status display	iREC	Indicates the interval recording mode. For further details, refer to "INTERVAL REC function" (page 28).
③ Time code display	TCG 12:59:59:29 TCR 12:59:59:29 UBG AB:CD:EF:00 UBR AB:CD:EF:00 CNT 01:59:59	Indicates the TCG (time code generator) value. Indicates the TCR (time code reader) value. Indicates the UBG (user's bit generator) value. Indicates the UBR (user's bit reader) value. Indicates the COUNTER (counter) value.
④ Center marker	+	Displayed when ON is selected as the CENTER MARK (see page 35) setting. It indicates the center of the viewfinder screen.
⑤ 1st line message display (changes in switch settings)	AWB Ach *.K AWB Ach *.K UNDER AWB Ach *.K OVER AWB Bch *.K AWB Bch *.K UNDER AWB Bch *.K OVER AWB PRE *.K AUTO KNEE ON AUTO KNEE OFF GAIN **dB FILTER * SHUTTER OFF SHUTTER 1/** IRIS MODE **** FULL AUTO ON FULL AUTO OFF SCENE FILE USER SCENE FILE 1 SCENE FILE 2 SCENE FILE 3 SCENE FILE 4 SCENE FILE STD	Displayed when the AWB has been attained for channel A. Displayed when the AWB has been attained for channel A, and the color temperature is lower than the display range. Displayed when the AWB has been attained for channel A, and the color temperature is higher than the display range. Displayed when the AWB has been attained for channel B. Displayed when the AWB has been attained for channel B, and the color temperature is lower than the display range. Displayed when the AWB has been attained for channel B, and the color temperature is higher than the display range. Displayed when AWB has been switched to PRE. Displayed when AUTO KNEE has been changed from OFF to ON. Displayed when AUTO KNEE has been changed from ON to OFF. Displayed when the gain has been switched. Displayed when the filter has been switched. Displayed when the shutter has been set to OFF. Displayed when the shutter has been set to ON. Displayed when the IRIS MODE switch setting has been changed. Displayed when FULL AUTO has been changed from OFF to ON. Displayed when FULL AUTO has been changed from ON to OFF. } Displayed when the scene file dial setting has been switched.
(AWB, ABB operation displays)	AWB ACTIVE AWB OK *.K AWB OK *.K UNDER AWB OK *.K OVER AWB NG AWB PRE ATW MODE ABB ACTIVE ABB OK ABB NG	Displayed while the AWB operation is in progress. Displayed when AWB is completed error-free. Displayed when AWB is completed error-free, and the color temperature is outside the display range (under **K). Displayed when AWB is completed error-free, and the color temperature is outside the display range (over **K). Displayed when AWB is completed with an error. Displayed when AWB cannot be performed because AWB is set to PRE. Displayed when ATW (full time auto white balance) is in progress. Displayed while the ABB operation is in progress. Displayed when ABB is completed error-free. Displayed when ABB is completed with an error.
⑤ 2nd line message display (error result message displayed after AWB or ABB has been performed)	color temp LOW color temp HIGH LEVEL OVER LOW LIGHT UNSTABLE CONDITION TIME OVER	Warns that the color temperature is too low during the AWB operation. Warns that the color temperature is too high during the AWB operation. Warns that the brightness is too high during the AWB operation. Warns that the brightness is too low during the AWB operation. Warns that the screen is not stable during the AWB or ABB operation. Warns that the AWB or ABB processing could not be completed within the allotted time.
⑥ IRIS MODE switch status display	SPOT BACK	Displayed when the IRIS MODE switch is at the SPOT.L position. Displayed when the IRIS MODE switch is at the BACK.L position.
⑦ QUICK FOCUS display	QUICK FOCUS	Displayed when QUICK FOCUS is ON.

Viewfinder displays

Display item	What is displayed	Status causing the display to appear
8 Shutter speed	1/**.* 1/100 - 1/2000 SUPER V	Displayed when the shutter speed has been set to SYNCHRO SCAN. Displayed when a fixed shutter speed has been set. Displayed when SUPER V (high vertical resolution mode) has been set.
9 LOW LIGHT warning display	LOW LIGHT	Displayed when the brightness has been reduced.
10 AUDIO sampling frequency display	48k 32k	Indicates that a frequency of 48 kHz has been selected. Indicates that a frequency of 32 kHz has been selected. <Note> With a 1394 input, the input status is displayed.
11 Audio level meter display	- - - - - + - - + - - - - - + - - +	Indicates the audio levels of CH1 and CH2 (see page 27).
12 VTR warning display/voltage warning display	REC WARNING SLACK E-** HUMID SERVO RF TAPE NEAR END TAPE END BATT NEAR END BATT END MP TAPE BACKUP BATT EMPTY	Indicates the occurrence of an error during recording. Indicates the occurrence of an error caused by the mechanism. Depending on the type of error, the power may be cut off automatically. (*1) Indicates that condensation has formed. Servo lock is not engaged during recording or playback. The signal level from the tape has dropped. The tape is nearing its end (there are about 2 minutes left). The tape has stopped at the tape end. The battery is nearly flat. The tape has stopped because the battery is flat. An MP tape has been loaded. The tape is automatically ejected. It is time to replace the backup battery.
13 FULL AUTO/SCENE FILE display	FULL Filename which has been set	Displayed when the FULL AUTO switch has been set to ON. Indicates the filenames (8 characters) set for the scene files.
14 AWB color temperature fine adjustment amount display	AWB+**	The adjustment amount is displayed when ON has been selected as the "COLOR TEMP" setting (see page 32) and the color temperature has been adjusted finely. It is not displayed when OFF is selected or only ATW has been set.
15 Zoom display	Z00 - Z99	Indicates the zoom amount. However, most 1/2-inch size lenses have no zoom position return. In such a case, this item is not displayed even if ON has been selected as the display setting.
16 AWB color temperature display	*.*K	Indicates the color temperature.
17 ATW, AWB channel display	Ach Bch PRE ATW	The WHITE BAL switch has been set to channel A. The WHITE BAL switch has been set to channel B. The WHITE BAL switch has been set to PRE. The full time auto white balance has been set.
18 F value display	NC OPEN F2.0 - F16 CLOSE	Displayed when the lens cable has not been connected. Displayed when the lens iris has been opened. Indicates the lens iris value. Displayed when the lens iris has been closed. <Note> This item appears when using a lens equipped with a function that displays the aperture value.
19 Gain display	0 - 36dB	Displays the current gain value.
20 Filter display	FL1 - FL4 FL-	Displays the filter position. Displayed when filter has not been set to the proper position.

*1: For details on the codes displayed, refer to "Error codes" (page 40).

Viewfinder displays

Display item	What is displayed	Status causing the display to appear
① Calendar/clock display	01-01-01 00:00:00	The 24-hour system is used for the clock display. (Month-day-year and hours-minutes-seconds displayed)
② Voltage display	**.*V	The input voltage is displayed.
③ Calendar/clock status switching display	D	"D" is displayed only when a VF DISPLAY setting has been selected. This is to enable the user to differentiate between the screen displays when "TIME+DATE" (see page 35) has been selected as the TIME/DATE setting on <VF DISPLAY 2/2> and when "REC" has been selected as the TIME STAMP setting (see page 34) on <VTR OPTION>.
④ Remaining tape/recording inhibit display	**.*min END INH	Normally, "**.*min" is lighted, and it flashes when the tape is nearly at its end. When the tape reaches the end, "END" lights. When recording is inhibited, "INH" lights.
	IND+003	This lights during an INDEX search. A positive number denotes an index count in the forward direction, and a negative number denotes an index count in the reverse direction. With each detection, the value is decremented to zero, and when the tape stops, the remaining tape display is restored.
⑤ Safety zone markers	Corner: 3 types Box: 3 types 16:9 full box: 3 types	The safety zone markers selected for 01 through 09 in SAFETY ZONE are displayed. For further details, refer to the table for "SAFETY ZONE" (page 35) on the <MARKER/ZEBRA> sub-menu.
⑥ Cause of !LED lighting display (this item appears only during a MODE check)	SUPER-V EXT ON FIL No1 FIL wo No1 FIL NG SHUT wo 1/100 SHUT ON WHITE ATW WHITE PRE GAIN wo 0dB	Displayed when SUPER-V is set to ON. Displayed when EXTENDER is set to ON. Displayed when FILTER is set to 1. Displayed when FILTER is set to a number other than 1. Displayed when FILTER is set to NG. Displayed when SHUTTER is set to a speed other than 1/100. Displayed when SHUTTER is set to ON. Displayed when ATW has been selected for AWB. Displayed when the AWB switch has been set to PRE. Displayed when a gain value other than 0 dB has been selected.

Selecting the viewfinder screen display

	Status displayed when the corresponding status is established	Display/non-display selected by MARKER/ZEBRA	Display/non-display selected by VF DISPLAY 1/2 or 2/2	Displayed and can be cleared	Displayed during playback
① Extender display	○	-	○	○	-
② INTERVAL REC status display	○	-	-	-	-
③ Time code display	-	-	○	○	○
④ Center marker	-	○	-	○	-
⑤ Message display	○	-	-	-	-
⑥ IRIS MODE switch status display	○	-	○	○	-
⑦ QUICK FOCUS display	○	-	-	-	-
⑧ Shutter speed display	○	-	○	○	-
⑨ LOW LIGHT warning display	○	-	○	○	-
⑩ AUDIO sampling frequency display	-	-	○	○	○
⑪ Audio level meter display	-	-	○	○	○
⑫ VTR warning display/voltage warning display	○	-	-	-	○
⑬ FULL AUTO/SCENE FILE display	○	-	○	○	-
⑭ AWB color temperature fine adjustment amount display	○	-	○	○	-
⑮ Zoom display	-	-	○	○	-
⑯ AWB color temperature display	-	-	○	○	-
⑰ ATW, AWB channel display	-	-	○	○	-
⑱ F value display	-	-	○	○	-
⑲ Gain display	-	-	○	○	-
⑳ Filter display	-	-	○	○	-
㉑ Calendar/clock display	-	-	○	○	-
㉒ Voltage display	-	-	○	○	-
㉓ Calendar/clock status switching display	○	-	-	-	-
㉔ Remaining tape/recording inhibit display	-	-	○	○	-
㉕ Safety zone markers	-	○	-	○	-

White balance and black balance adjustment

Better pictures will be produced by performing the white balance and black balance adjustments in the sequence of AWB (white balance adjustment) → ABB (black balance adjustment) → AWB. Normally, there is no need to re-adjust the black balance even when the power is turned on again.

<Notes>

Even though the brightness under artificial lighting and especially under fluorescent lights and mercury lamps may appear to be constant, the strengths of the red, green and blue colors change in synchronization with the power line frequency. Particularly in areas where this frequency is 50 Hz, the unit's vertical sync frequency (approx. 60 Hz) and the lighting frequency (50 Hz) will be subject to mutual interference, causing the color phase to change as time passes and flicker to be generated. This makes it impossible to attain the white balance properly. It is recommended that the white balance be attained using the settings shown in the table below.

Power line frequency	Shutter speed
50Hz	1/100
60Hz	OFF

Automatic white balance adjustment

1 Set the switches to the positions shown in the figure.

- ① Set the WHITE BAL switch to A or B.
- ② Set the OUTPUT/AUTO KNEE switch to CAM.
- ③ Normally, set the GAIN selector switch to 0 dB. If it is too dark at this setting, set the gain to a more appropriate level.
- ④ Set the CC/ND filter selector knob to the position corresponding to the lighting conditions.

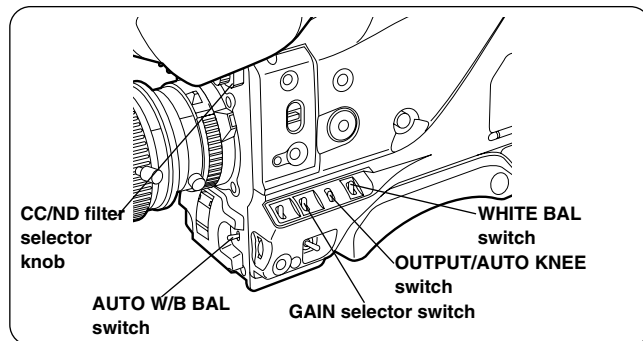

2 Erect a white pattern at a location subject to the same conditions as the light source illuminating the subject, zoom in, and fill the screen with white.

Something white (a piece of white fabric or a white wall) near the subject can be used instead. The required size of the white object is shown in the figure below.

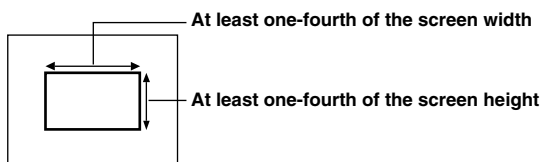

<Note>

Do not allow any high-brightness spots inside the screen.

3 Adjust the lens iris.

4 Push the AUTO W/B BAL switch to AWB and release it.

The switch returns to the center, and the white balance is automatically adjusted.

5 A message corresponding to the AWB execution status appears inside the viewfinder.

For details, refer to the viewfinder displays (page 16).

<Notes>

If the black balance adjustment was not completed without an error, an error message appears inside the viewfinder. Try performing the adjustment again.

If the error message persists even after another attempt at adjustment, consult your dealer or a Panasonic Service Center representative.

<Reference>

If there is no time to adjust the white balance, set the WHITE BAL switch to PRST. The white balance will be attained for the filter according to the FILTER control (outer) setting position.

The automatic tracking white balance operation is performed when ATW has been set ahead of time for the A, B and PRE positions of the WHITE BAL switch: this comes in handy at such a time.

Automatic black balance adjustment

The black balance must be adjusted in the following cases.

- When the unit is to be used for the first time
- When the unit is to be used after it has not been used for a prolonged period
- When the unit is to be used where the ambient temperature has changed significantly
- When the gain selection value has been changed
- When the MASTER GAMMA setting has been changed

1 Push the AUTO W/B BAL switch to ABB and release it.

The switch returns to the center, the iris is automatically set to the shielded mode, and the adjustment is performed.

2 A message corresponding to the ABB execution status appears inside the viewfinder.

For details, refer to the viewfinder displays (page 16).

<Notes>

If the black balance adjustment was not completed without an error, an error message appears inside the viewfinder. Try performing the adjustment again.

If the error message persists even after another attempt at adjustment, consult your dealer or a Panasonic Service Center representative.

The gain switching circuit is automatically switched while the black balance is being adjusted. Although flicker or noise may appear on the viewfinder screen, this is not indicative of malfunctioning.

Electronic shutter settings

Concerning the shutter modes

Shutter modes and shutter speeds that can be set

Mode	Shutter speed	Applications
Standard	1/100, 1/120, 1/250, 1/500, 1/1000 and 1/2000 (sec.)	For shooting fast-moving subjects clearly
SYNCHRO SCAN	Within the 60.3 Hz to 250.0 Hz range	For shooting monitor screens with minimal striping in the horizontal direction
SUPER V		For improving the vertical resolution

<Notes>

- Whatever mode is set for the electronic shutter, the faster the shutter speed, the lower the camera's sensitivity.
- In the automatic iris mode, the faster the shutter speed, the more the iris opens and the shallower the depth of focus.
- When SUPER V has been selected, the camera's sensitivity will be halved.

Setting the shutter mode and speed

- In the shutter speed and standard mode, the shutter speed is set by selecting the SHUTTER switch position.
- In the SYNCHRO SCAN mode, the shutter speed can be easily changed by operating the JOG dial button.

1 Push the SHUTTER switch from ON to SEL.

The current shutter setting appears in the area of the viewfinder screen where messages notifying the user of changes made to settings appear.

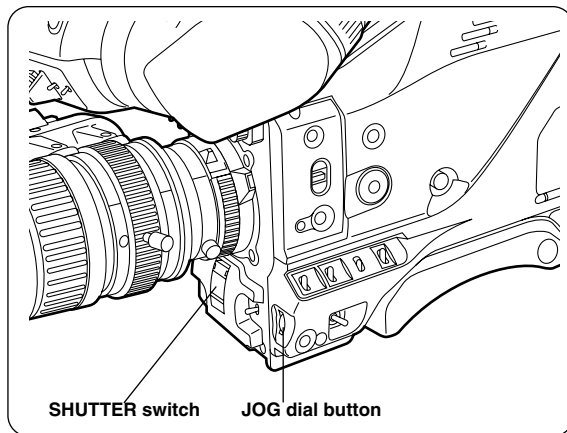

2 Press the SHUTTER switch to SEL again, and repeat until the desired mode or speed is displayed.

When all the modes and speeds are displayed, the display changes in the following sequence.

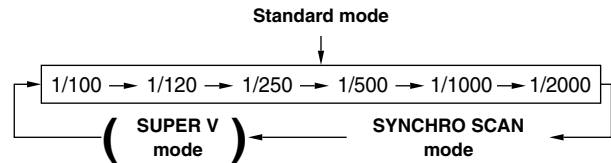

<Note>

The SUPER V mode is not selected as the factory setting. For this reason, it is not displayed at the factory setting.

To select SUPER V mode, set the "SUPER V" of the sub-menu <SW MODE> screen to ON. (See page 37)

Setting the synchro scanning mode

1 Push the SHUTTER switch from ON to SEL and set to SYNCHRO SCAN.

The setting can be continuously selected within the 60.3 Hz to 250.0 Hz range by rotating the JOG dial button up or down.

<Note>

After the JOG dial button is rotated up or down while being pressed, the setting will continue to change as long as the button is pressed (even without the button being rotated).

Time data settings

When both the user's bit and time code are to be used, the user's bit is set first.
The time code can be set from 00:00:00:00 to 23:59:59:29.

Setting the user's bit

By setting the user's bit, memos (date, time) and other information consisting of up to 8 hexadecimal digits can be recorded on the sub-code track.

1 Set the COUNTER/TC/UB switch to UB.

2 Set the TCG switch to SET.

"UBG **:**:**:**" now appears in the viewfinder. Select a number for the flashing part by rotating the JOG dial button, and press the JOG dial button to enter it. When the number is entered, the flashing moves to the next characters on the right so that another number can be input in the same way until the user's bit is set.

3 Set the TCG switch to F-RUN or R-RUN.

4 Select the "UB MODE" on the sub-menu <VTR FUNCTION> screen. (See page 34)

Concerning the user's bit memory function

The user's bit settings (except for the actual time) are automatically stored in the memory and retained even after the power has been turned off.

<Notes>

- When DATE is selected for "UB MODE" on the sub-menu <VTR FUNCTION>, the year/month/day on the TIME/DATE screen will function in real time.
- When TIME is selected for "UB MODE" on the sub-menu <VTR FUNCTION>, the hours/minutes/seconds on the TIME/DATE screen will function in real time.

Setting the time code

1 Set the COUNTER/TC/UB switch to TC.

2 Set the TCG switch to SET.

"TCG **:**:**:**" now appears in the viewfinder. Set the time code by performing the same operations used to set the user's bit.

3 Set TC MODE to DF or NDF on the sub-menu <VTR FUNCTION> screen.

Set this to DF to advance the time code in the drop frame mode or NDF to advance it in the non-drop frame mode.

4 Set the TCG switch.

Set this to F-RUN to advance the time code in the free-run mode or R-RUN to advance it in the rec-run mode.

<Note>

The backup accuracy of the time code will be out by several frames when the POWER switch has been set from ON to OFF and then back to ON again.

Scene files

Scene file function

The values of the camera setup tailored to different shooting conditions can be stored in the unit's memory in the form of files. During shooting, the file required can be called instantly simply by turning the SCENE FILE dial.

The following six files were stored in the memory before the unit was shipped from the factory.

USER: FACTORY (user file)

F1 : FLUO. (fluorescent light file)

This file's settings establish the mode which is best suited to indoor shooting where the characteristics of fluorescent lights are taken into consideration.

F2 : SPARKLNG (sparkling file)

This file's settings establish the mode which is best suited to wedding receptions, etc. where the subject is to be livened up.

F3 : COOL (cool file)

This file's settings establish the mode which is best suited to outdoor shooting to produce images with an overall bluish tinge.

F4 : RETRO (retro file)

This file's settings establish the mode for producing images with an overall reddish tinge to create the atmosphere of bygone days.

STD : FACTORY (standard file)

Scene file setting method

The scene file settings are changed using the SCENE FILE dial and the sub-menu <SCENE FILE> screen.

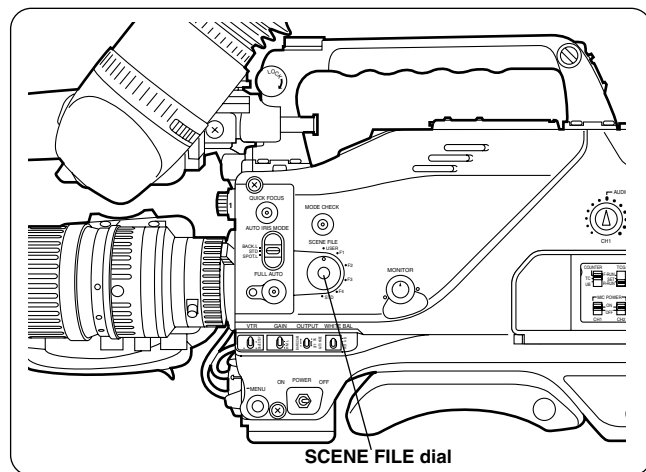

Editing scene filenames

(example: USER file)

- 1 Rotate the SCENE FILE dial to select the scene file whose name is to be changed.
- 2 Proceed with the menu operations (page 30) to open the <SCENE FILE> screen.
- 3 Rotate the JOG dial button to move "→" to the NAME EDIT item, and press the JOG dial button.

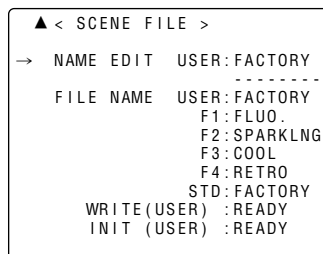

- 4 Rotate the JOG dial button to move "↓" to a point above the character of the filename to be changed.
- 5 When the JOG dial button is pressed, the "↓" position flashes, and the input mode is established.

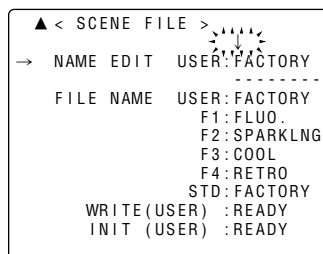

- 6 Rotate the JOG dial button until the next character to be changed appears.

When the button is turned, the character display is switched in the following sequence:

- Space:
- ↓
- Letters of the alphabet: A through Z
- ↓
- Numbers: 0 through 9
- ↓
- Symbols: ', >, <, /, -

- 7 Press the JOG dial button to enter the character.
- 8 Rotate the JOG dial button to move the arrow (cursor) to the next position (on the right), and repeat steps 5, 6 and 7 to enter the remaining characters. (Not more than 8 characters may be used for a filename.)

To change the ↓ back to →, press the JOG dial button when the ↓ is above the colon (:).

Scene files

9 Rotate the JOG dial button to move “→” to the WRITE item.

```
▲ < SCENE FILE >
NAME EDIT  USER:TARO
-----
FILE NAME  USER:FACTORY
           F1:FLUO.
           F2:SPARKLNG
           F3:COOL
           F4:RETRO
           STD:FACTORY
→ WRITE(USER) :READY
   INIT (USER) :READY
```

10 When the JOG dial button is pressed, the following message is displayed.

```
▲ < SCENE FILE >
NAME EDIT  USER:TARO
-----
FILE NAME  USER:FACTORY
           F1:FLUO.
           F2:SPARKLNG
           F3:COOL
           F4:RETRO
           STD:FACTORY
→ WRITE(USER) :NO
   INIT (USER) :READY
```

11 Rotate the JOG dial button to select YES, and press the JOG dial button.

When the data has been written (saved), the following message is displayed.

```
▲ < SCENE FILE >
NAME EDIT  USER:TARO
-----
FILE NAME  USER:TARO
           F1:FLUO.
           F2:SPARKLNG
           F3:COOL
           F4:RETRO
           STD:FACTORY
→ WRITE(USER) :OK
   INIT (USER) :READY
```

<Note>

Repeat step 11 if the NG display appears.

12 Press the MENU button to exit the menu operation.

The setting menu is cleared, and the displays showing the unit's current statuses appear on the viewfinder screen.

Returning a scene filename to its default

Rotate the JOG dial button to move “→” to the INIT item, and perform steps 10 and 11 of “Editing scene filenames” in the previous section.

The scene filenames are returned to their defaults (factory settings).

<Note>

The scene file setting data are also returned to their default values.

How to use file select

Up to four menu setting parameters other than scene files can be stored in the memory. These parameter are MAIN 1/2 and MAIN 2/2 menu items. For further details, refer to “List of file settings” (page 25).

Files are written and read on the sub-menu <DATA READ/WRITE> screen (page 33). When the unit was shipped from the factory, the default values (factory settings) were stored in four files.

Proceed with the menu operations (page 30) to display the sub-menu <DATA READ/WRITE> screen.

1 Operate the JOG dial button to select 1, 2, 3 or 4 as the FILE SELECT number.

```
▲ < DATA READ/WRITE >
→ FILE SELECT :1
FILE READ (1):READY
FILE WRITE(1):READY
READ FACTORY :READY
```

2 Proceed with writing setting statuses in a file or calling them from a file.

- ① To write the unit's setting statuses in the file with the selected number when the file is selected, execute FILE WRITE (*). (where the number of the selected file is input into “*”).
- ② To call the unit's setting statuses from the file with the selected number, execute FILE READ (*).
- ③ To return to the default statuses, execute READ FACTORY.

For details on this operation, refer to the scene file settings.

Scene files

List of scene file settings

The scene file factory settings are listed in the tables below.
Use them as a reference when making changes to a USER file.

Setting item	F1	F2	F3	F4	STD	USER	Remarks
<SCENE FILE NAME>	FLUO.	SPARKLNG	COOL	RETRO	FACTORY	FACTORY	
<IRIS/GAMMA>							
A. IRIS LEVEL	0	0	0	0	0	0	
A. IRIS PEAK/AVE	PEAK, 0	PEAK, 0	PEAK, 0	PEAK, 0	PEAK, 0	PEAK, 0	
A. IRIS SPEED	0	0	0	0	0	0	
BLACK STR/PRESS	NORM	NORM	NORM	NORM	NORM	NORM	
MASTER GAMMA	0	0	0	-10	0	0	
<COLOR/SKIN TONE>							
PRE COLOR TEMP	0	0	0	0	0	0	
Ach	0	0	+10	-20	0	0	
Bch	0	0	+10	-20	0	0	
SKIN TONE DTL	OFF	OFF	OFF	OFF	OFF	OFF	
SKIN TONE RANGE	NORM	NORM	NORM	NORM	NORM	NORM	
<PROCESS>							
H DETAIL	0	+5	+5	-5	0	0	
V DETAIL	0	+5	+5	-4	0	0	
DTL CORING	0	+5	+5	0	0	0	
H. DTL FREQ.	3 MHz	3 MHz	3 MHz	3 MHz	3 MHz	3 MHz	
MATRIX	B	A	A	A	A	A	
CHROMA LEVEL	+2	+2	0	0	0	0	
CHROMA PHASE	0	0	0	0	0	0	
MASTER PED	0	0	0	0	0	0	
KNEE POINT	88%	88%	88%	88%	88%	88%	

List of file settings

The items which can be selected by the file select function are listed in the tables below.
The factory settings have been set for all the default values.
Changes can be made to the settings in file numbers 1 to 4 to suit the prevailing application in mind.

Setting item	1 to 4	Remarks	Setting item	1 to 4	Remarks	Setting item	1 to 4	Remarks
<SW MODE>			<BATTERY>			<VF DISPLAY 1/2>		
LOW GAIN	0 dB		BATTERY SELECT	NiCd14		FILTER	ON	
MID GAIN	9 dB		TYPE A NEAR END	11.6 V		GAIN	ON	
HIGH GAIN	18 dB		TYPE A END	11.2 V		WHITE BAL	ON	
ATW	OFF		TYPE B NEAR END	12.7 V		COLOR TEMP	ON	
SUPER V	OFF		TYPE B END	12.4 V		IRIS (F Number)	ON	
QUICK FOCUS	ENABLE		<MIC/AUDIO>			ZOOM	ON	
FULL AUTO	ENABLE		FRONT MIC POWER	ON		TCG	TCG/TCR	
SCENE FILE	ENABLE		FRONT MIC	-50 dB		LEVEL METER	CH1+CH2	
<VIDEO IN/OUT>			REAR MIC CH1	-60 dB		TAPE REMAIN	ON	
VIDEO OUT MENU	ON		REAR MIC CH2	-60 dB		BATTERY	ON	
VIDEO OUT SEL	ENC		MIC LOWCUT CH1	ON		<VF DISPLAY 2/2>		
INPUT SELECT	CAMERA		MIC LOWCUT CH2	ON		SHUTTER SPEED	ON	
REMOTE SELECT	LOCAL		LINE CH1	-6 dB		IRIS (SPOT, BACK)	ON	
SET UP	0 %		LINE CH2	-6 dB		AUTO/SCENE NAME	ON	
<VTR FUNCTION>			<MARKER/ZEBRA>			LOW LIGHT	ON	
TC MODE	DF		SAFETY ZONE	06		TIME/DATE	OFF	
UB MODE	USER		CENTER MARK	ON		EXTENDER	ON	
FIRST REC TC	REGEN		ZEBRA1 DETECT	70%		AUDIO SAMPLING	ON	
BACK TALLY	ON		ZEBRA2 DETECT	85%		<! LED>		
FF/REW SPEED	x100		ZEBRA2	SPOT		GAIN	W/O 0 dB	
AUDIO SAMPLING	48 K		VF DTL	1		WHITE	OFF	
<VTR OPTION>						SHUTTER	ON	
TIME STAMP	NO-REC					FILTER	NG	
REC TIME	00m05s					EXTENDER	ON	
INTERVAL TIME	00h0m010s					SUPER V	OFF	
PAUSE TIMER	10 min							

Normal recording

Recording methods

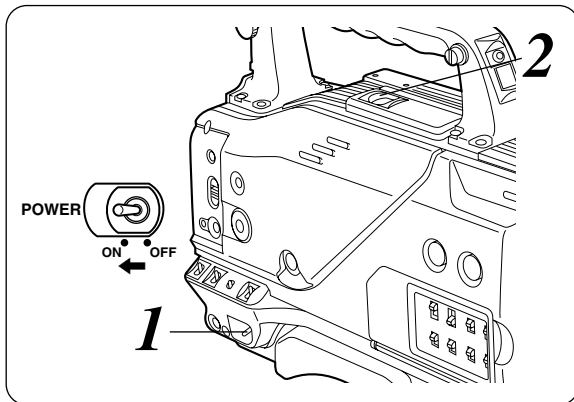

1 Set the POWER switch to ON.

2 Press the EJECT button to open the cassette compartment, and insert the cassette tape.

- Before proceeding with the recording, check that the cassette tab has been set to the REC position.
- This unit is used exclusively for standard cassettes.

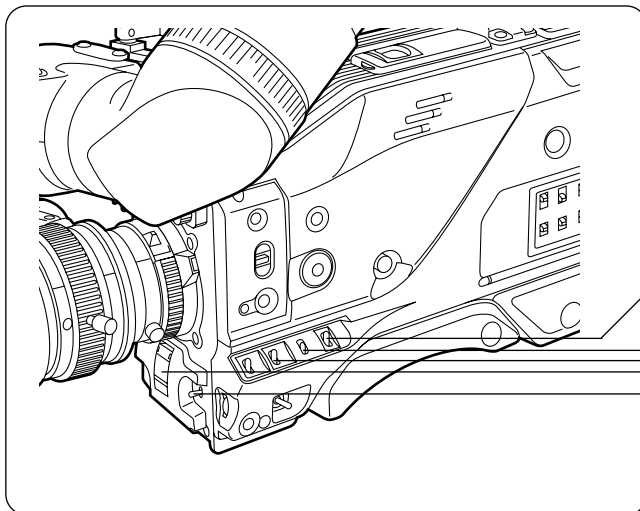
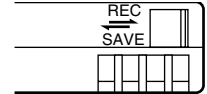

3 Set the camera unit's switches as follows.

Use the white balance selector switch to select the desired white balance mode.

Set the OUTPUT selector switch to CAM.

Set the GAIN selector switch to the setting that supports the subject brightness.

Select the desired shutter speed as required. (Normally, the shutter is used at the OFF setting.)

When the white balance selector switch is set to A or B, adjust the white balance.

- For details on the above switches, refer to "Parts and their functions" (pages 6-8).

4 Point the camera at the subject, and adjust the lens iris, focus and zoom.

5 Press the VTR START/STOP button to start the recording.

6 Press the VTR START/STOP button to stop the recording.

Scene-to-scene continuity

Scene-to-scene continuity is possible after the tape has been allowed to run or after the cassette has been ejected or when ensuring continuity on a tape which has been recorded only in part.

1 While monitoring the viewfinder screen, press the PLAY/PAUSE button to play back the tape.

2 At the place on the tape where continuity is to be maintained, press the PLAY/PAUSE (or STOP) button again to stop the tape.

3 Press the lens RET button. It takes about two seconds to complete the preparations for the scene-to-scene continuity.

4 Press the VTR START button or lens VTR button to start the recording.

Audio recording

Selecting the audio input signals

1 Select the desired input signals using the AUDIO IN switch.

To use the front microphone	→ Select FRONT (MIC).
To use the rear microphone	→ Select REAR (MIC).
To use the audio products	→ Select REAR (LINE).

<Note>

- When the front microphone has been selected, select ON as the <FRONT MIC POWER> setting for the MIC/AUDIO sub-menu item if the phantom mic (+48V) needs to be supported. (See page 35)
- When the exterior microphone is selected and phantom mic (+48V) needs to be supported, set the mic power switch to ON.

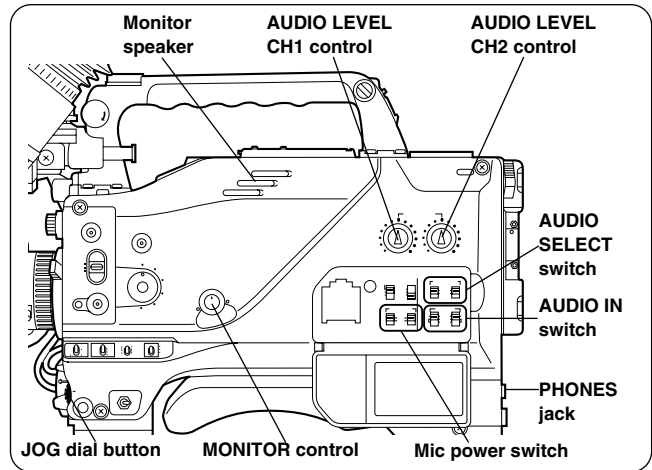

Adjusting the audio recording level

When the AUTO SELECT CH1/CH2 selector switch is set to AUTO, the input levels of the CH1 and CH2 sound are automatically adjusted.

To adjust the input levels of the CH1 and CH2 sound manually, proceed as follows

1 Set the AUTO SELECT CH1/CH2 selector switch to MAN.

2 While monitoring the audio level meter inside the viewfinder, adjust the AUDIO LEVEL CH1 and CH2 controls in such a way that the maximum input level does not exceed “-----+--+.”

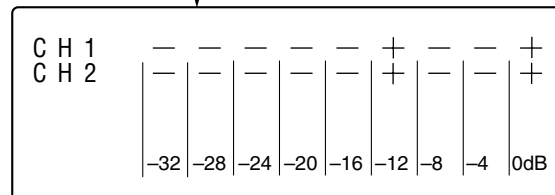
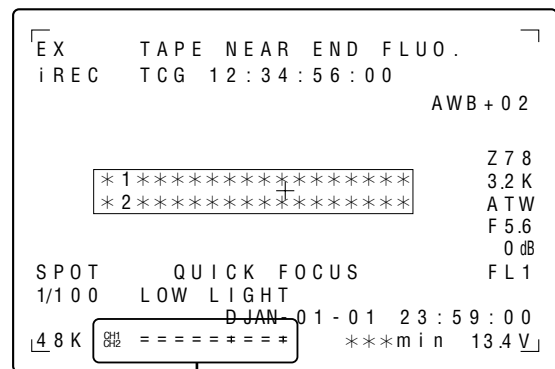

Monitoring the sound during recording

The audio input signals can be monitored through the monitor speaker or earphone. When the PHONES jack is used, no sound will be heard through the monitor speaker.

The volume of the monitored sound can be adjusted using the MONITOR control.

<Note>

Howl may be caused if the volume of the audio monitor speaker is too high. In a case like this, rotate the audio monitor level control to a lower level which does not give rise to howl.

Playback (checking what has been recorded)

When the PLAY/PAUSE button is pressed, the playback images can be viewed in black and white on the viewfinder screen. At the same time, color playback images can be monitored from the VIDEO OUT connector.

Rec review

When recording is temporarily stopped and the RET button on the lens is pressed, the last two seconds of the recording on the tape is automatically rewound, and the playback images for those seconds appear in the viewfinder. These functions makes it possible to check whether the recording has been performed as intended.

After the images have been played back, the recording start standby status is restored.

If the RET button is held down, up to 10 seconds on the tape can be rewound and played back.

<Notes>

- The rec review function cannot be used unless the recording is at least one second long.
- During the rec review operation, the rec review images are output to not only the viewfinder but the video output connectors (VIDEO OUT connector, S-VIDEO connector) as well. Bear in mind that the rec review images will be recorded on a backup VTR if a back VTR has been connected and backup images are being recorded.

Other functions

Still-picture playback

When the PLAY button is pressed during playback, the PLAY lamp flashes, the still-picture mode is established, and still pictures can be played back

If the PLAY button is pressed again, normal playback is resumed.

INTERVAL REC (intermittent recording) function

This unit is capable of simple interval shooting (intermittent recording). This function is very useful for shooting programs with nature themes and art programs.

The INTERVAL REC function settings are selected on the sub-menu VTR OPTION screen.

- **INTERVAL REC:**
This sets the INTERVAL REC function ON, OFF or ONE SHOT.
- **REC TIME:**
This sets the recording time (1 cut) for interval shooting.
- **INTERVAL TIME:**
This sets the rec pause time for interval shooting.

When the items above are set, the INTERVAL REC mode is established, and "i" starts flashing in the viewfinder.

When the VTR START button is pressed, interval shooting starts, and the flashing "i" changes to a lighted "i REC."

When the first interval shooting is completed and the rec pause mode is established, "i REC" which had remained lighted now starts flashing in the viewfinder.

When "I REC" is set, the POWER/WARNING LED flashes in green.

<Note>

To release the INTERVAL REC mode, press the VTR START button during recording or press the STOP button during Rec Pause.

Variable speed (FF/REW) playback

- When the FF (fast forward) or REW (rewind) button is pressed during playback, playback is performed at 4X normal speed in the forward or reverse direction. When it is pressed again, playback is performed at 8X normal speed in the forward or reverse direction.
- By pressing the button again, it is possible to switch playback from 4X to 8X normal speed or vice versa.

INDEX SEARCH mode

Index areas can be searched in this mode.

- With the unit in the stop mode, press the REW or FF button while holding down the mode check button.
- During the INDEX SEARCH operation, a display such as "IND + 001" appears at the remaining tape display position in the viewfinder. "+" indicates the forward direction and "-" denotes the reverse direction while the number indicates how many times the index areas are to be detected before the operation stops.
- The index area is searched in the forward or reverse direction for the number of times that corresponds to the number of times the FF or REW button was pressed.

Example: Press the REW button 3 times.

→ The third index area back from the stop area is searched. (Viewfinder display: IND -003)

Press the FF button twice.

→ The second index area ahead from the stop area is searched. (Viewfinder display: IND +002)

- To stop index search at any time, press the STOP button. Operation stops at the tape position where the button was pressed.

<Note>

The maximum INDEX SEARCH number is -127 in the reverse direction and +128 in the forward direction.

Using the unit with external components

Connection to a video component with a DV connector

The unit can be used as a player or recorder by connecting it to a video component equipped with a DV connector using a DV cable. In either case, refer to the figure below for the connections.

Using the unit as a player

Select 1394 as the REMOTE SELECT setting on the sub-menu VIDEO IN/OUT screen. (See page 34)

The unit can now be controlled from the external video component with the DV connector.

Using the unit as a recorder

Select 1394 as the INPUT SELECT setting on the sub-menu VIDEO IN/OUT screen. (See page 34)

The pictures and sound of the external video component with the DV connector can now be recorded on the unit.

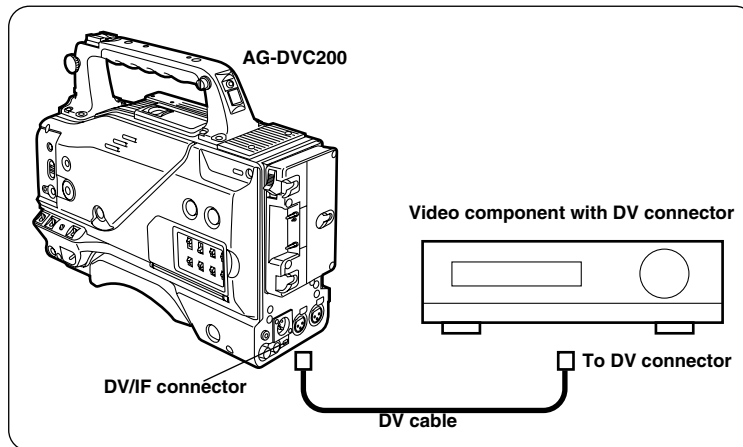

Connection to a PC capable of non-linear editing

By connecting the unit to a PC capable of non-linear editing using a DV cable, the unit can be controlled from the PC and pictures and sound can be input from or output to the PC.

Select 1394 as both the REMOTE SELECT and INPUT SELECT settings on the sub-menu VIDEO IN/OUT screen. Refer to the figure below for the connections. (See page 34)

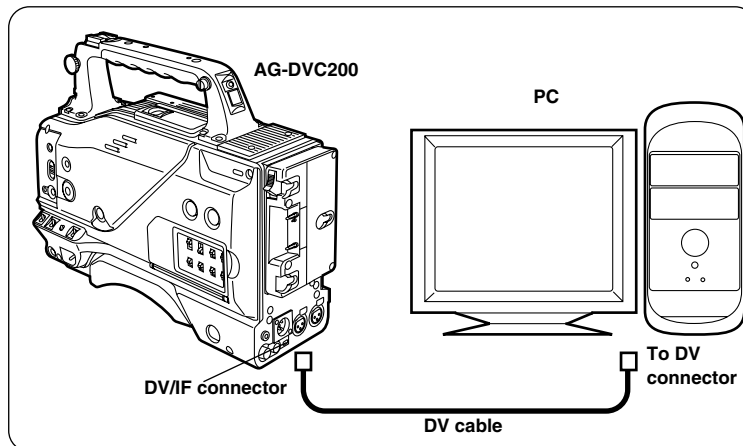

<Note>

When the unit is connected by cable to an exterior device, set the VTR STBY/SAVE switch to STBY to improve response by the unit.

Menu operations

The MENU button and JOG dial button are used for the setting menu operations. The menus consist of main menus and sub-menus. The data set on the sub-menus is saved in the non-volatile memory and stored for a prolonged period of time.

Menu display enable/disable

1 Press the MENU button.

The main menu SCENE screen is displayed.

2 When the JOG dial button is pressed, the main menu MAIN 1/2 screen is displayed.

3 When the JOG dial button is pressed, the main menu MAIN 2/2 screen is displayed.

4 When the JOG dial button is pressed again, the display returns to the SCENE screen.

5 To clear the menu screen, press the MENU button.

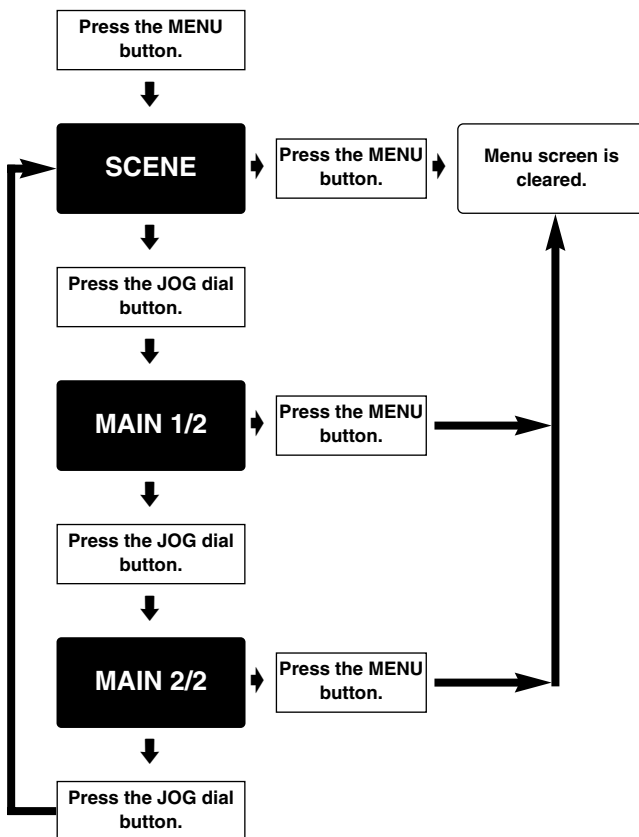

Displaying sub-menus and deciding on settings

1 Rotate the JOG dial button while the main menu is displayed.

The cursor moves to the sub-menu items.

2 Move the “→” to the desired sub-menu item, and press the JOG dial button.

The sub-menu screen now appears. (“→” appears at the sub-menu title.

Example: Rotate the JOG dial button.

```

    NEXT**** MAIN 2 / 2 ****
    →MARKER/ZEBRA..
    VF DISPLAY 1/2..
    VF DISPLAY 2/2..
    ! LED..
    GENLOCK..
    CAMERA ID..
    TIME/DATE..
    DIAGNOSTIC..
  
```

3 Rotate the JOG dial button to move the cursor to the sub-menu item to be changed, and press the JOG dial button. The setting now flashes.

Example: Rotate the JOG dial button.

```

    ▲ < MARKER/ZEBRA >
    → SAFETY ZONE :06
    CENTER MARK :ON
    ZEBRA1 DETECT :070%
    ZEBRA2 DETECT :085%
    ZEBRA2 :SPOT
    VF DTL :1
  
```

4 Rotate the JOG dial button to change the setting, and press the JOG dial button at the desired setting. The setting is now entered.

Example: Rotate the JOG dial button.

```

    ▲ < MARKER/ZEBRA >
    → SAFETY ZONE :06
    CENTER MARK :ON
    ZEBRA1 DETECT :070%
    ZEBRA2 DETECT :085%
    ZEBRA2 :SPOT
    VF DTL :1
  
```

5 If there is another item to be set, rotate the JOG dial button to move the cursor, and decide on the setting by performing steps 3 and 4.

6 To move to another sub-menu, rotate the JOG dial button to move the cursor to the sub-menu title, and press the JOG dial button.

The main menu screen now appears. Follow the same procedure.

7 Upon completion of the settings, press the MENU button.

The settings are stored in the memory, the setting menu mode is exited, and the normal operation mode is restored.

Setting menu configuration

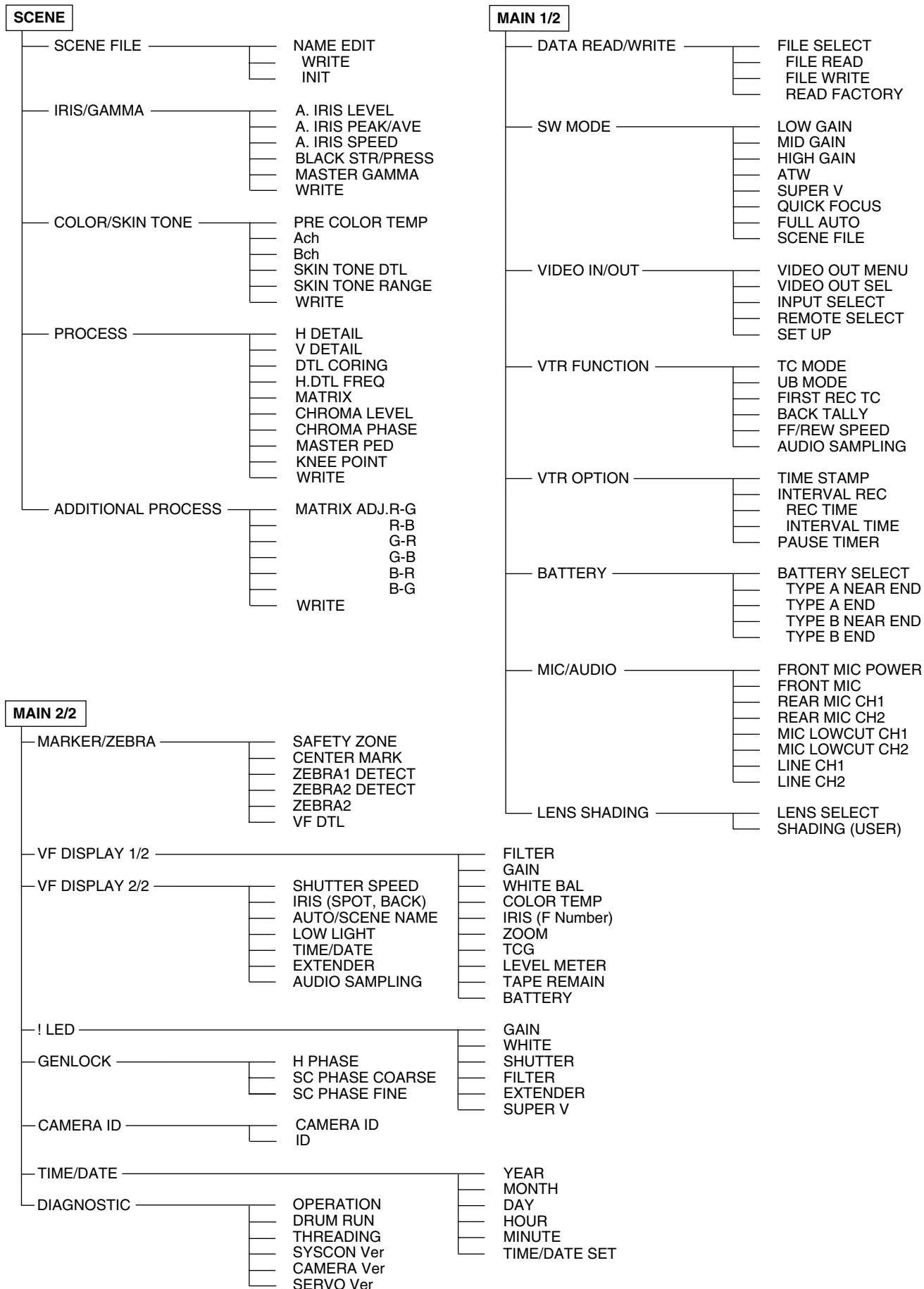

Menu contents

SCENE menu (main menu)

```

→NEXT**** SCENE ****
                F1:FLUO.
SCENE FILE..
IRIS GAMMA..
COLOR/SKIN TONE..
PROCESS..
    
```

SCENE FILE

Item	Setting options	Remarks
NAME EDIT	USER F1 - F4 STD	For editing scene filenames. For further details, refer to "Editing scene filenames" (page 23).
WRITE		For writing a scene filename.
INIT		For returning the scene filenames to their factory settings.

IRIS/GAMMA

Item	Setting options	Remarks
A. IRIS LEVEL	-10 : <u>+00</u> : +10	For setting the AUTO IRIS target value. The brightness (IRIS) is controlled using this value. The higher the setting, the brighter the images shot.
A. IRIS PEAK/AVE	AVE 10 : 01 <u>PEAK</u> <u>00</u> : 10	For setting the ratio between the AUTO IRIS peak value control and average value control. With a setting of 10 for AVE, control is exercised completely by the average value; with a setting of 10 for PEAK, control is exercised completely by the peak value.
A. IRIS SPEED	-2 : <u>+0</u> : +2	For setting the AUTO IRIS speed.
BLACK STR/PRESS	PRESS <u>NORM</u> STR	For selecting the low-brightness black rise. PRESS: The black is compressed, and the images appear tight. NORM: Standard setting STR: The black is extended, and the gradations in the dark areas are expanded.
MASTER GAMMA	-15 : <u>+00</u> : +05	For setting the master gamma.
WRITE		For saving the data.

COLOR/SKIN TONE

Item	Setting options	Remarks
PRE COLOR TEMP	-30 : <u>+00</u> : +30	For finely adjusting the color temperature from the white balance when the WHITE BAL switch is set to the PRE position. This does not function with the ATW mode.
Ach	-30 : <u>+00</u> : +30	For finely adjusting the color temperature from the white balance when the WHITE BAL switch is set to the A position. This does not function with the ATW mode.
Bch	-30 : <u>+00</u> : +30	For finely adjusting the color temperature from the white balance when the WHITE BAL switch is set to the B position. This does not function with the ATW mode.
SKIN TONE DTL	ON <u>OFF</u>	For setting the skin tone detail ON or OFF. When the skin tone detail is set to ON, the detail in the skin tone areas is reduced, diminishing the feeling of roughness in the skin. <Note> When ON has been set for SKIN TONE DTL and the SKIN TONE RANGE or SKIN TONE CORING menu item is being set, the SKIN TONE ZEBRA pattern will appear for 10 seconds.
SKIN TONE RANGE	<u>NORM</u> WIDE	For setting the skin tone detail range. NORM: Normal range WIDE: Wide range
WRITE		For saving the data.

“ _____ ” denotes the mode which was set at the factory.

Menu contents

SCENE MENU (main menu)

PROCESS

Item	Setting options	Remarks
H DETAIL	-10 : <u>+00</u> : +10	For setting the amount of detail in the horizontal direction.
V DETAIL	-05 : <u>+00</u> : +15	For setting the amount of detail in the vertical direction.
DTL CORING	-5 : <u>+0</u> : +5	For setting the amount of detail coring.
H.DTL FREQ.	2MHz 3MHz 4MHz	For setting the detail boost frequency in the horizontal direction.
MATRIX	A B ADJ	For selecting the color compensation matrix table. A: Standard setting B: For shooting under fluorescent lighting. ADJ: Changes to the MATRIX value set for <ADDITIONAL PROCESS>.
CHROMA LEVEL	-2 : <u>+0</u> : +2	For setting the chroma level.
CHROMA PHASE	-31 : <u>+00</u> : +31	For setting the chroma phase. The skin tone takes on a reddish tinge in the "+" direction.
MASTER PED	-26 : <u>+00</u> : +26	For setting the master pedestal level.
KNEE POINT	90% : 100%	For setting the knee point position.
WRITE		For saving the data.

ADDITIONAL PROCESS

Item	Setting options	Remarks
MATRIX ADJ. R-G	+00	This is effective when ADJ has been selected for the "MATRIX" item of <PROCESS>. The MATRIX table can be adjusted/set as desired.
R-B	+00	
G-R	+12	
G-B	+00	
B-R	+00	
B-G	+00	
WRITE		For saving the data.

MAIN menu 1 of 2 (main menu)

→NEXT**** MAIN 1 / 2 ****

```
DATA READ/WRITE..
SW MODE..
VIDEO IN/OUT..
VTR FUNCTION..
VTR OPTION..
BATTERY..
MIC/AUDIO..
LENS SHADING..
```

DATA READ/WRITE

Item	Setting options	Remarks
FILE SELECT	1/2/3/4	For storing the menu setting parameters in the memory. For further details, refer to "How to use file select." (page 28)

SW MODE

Item	Setting options	Remarks
LOW GAIN	0dB : 36dB	For setting the gain allocated to the LOW GAIN switch. A setting from 0 to 36 dB can be selected.
MID GAIN	0dB : 9dB : 36dB	For setting the gain allocated to the MID GAIN switch. A setting from 0 to 36 dB can be selected.
HIGH GAIN	0dB : 18dB : 36dB	For setting the gain allocated to the GAIN switch. A setting from 0 to 36 dB can be selected.
ATW	PRE Ach Bch OFF	For setting at which WHITE BAL switch position the full time auto white balance mode is to be enabled. PRE: ATW is enabled at the PRE position. Ach: ATW is enabled at the Ach position. Bch: ATW is enabled at the Bch position. OFF: Full time auto balance is not performed.
SUPER V	ON OFF	For selecting the vertical high resolution mode.
QUICK FOCUS	ENABLE DISABLE	For enabling or disabling the quick focus function.
FULL AUTO	ENABLE DISABLE	For enabling or disabling the full auto function.
SCENE FILE	ENABLE DISABLE	For enabling or disabling the scene file function. ENABLE: The scene file function is enabled. DISABLE: The scene file function is restricted to the user files.

"_____" denotes the mode which was set at the factory.

Menu contents

MAIN menu 1 of 2 (main menu)

VIDEO IN/OUT

Item	Setting options	Remarks
VIDEO OUT MENU	<u>ON</u> OFF	For selecting whether to output the menu screens to the VIDEO OUT connector. ON: The screens are output. OFF: The screens are not output. <Note> The VIDEO OUT MENU item is valid only when ENC has been selected as the VIDEO OUT SETTING setting.
VIDEO OUT SEL	<u>ENC</u> VF	For selecting whether the VTR signals or VF signals are to be output from the VIDEO OUT connector. ENC: VTR output VG: VF output
INPUT SELECT	<u>CAMERA</u> 1394	For selecting the input signals of the VTR to be recorded. CAMERA: Unit's camera signals 1394: Signals from 1394
REMOTE SELECT	<u>LOCAL</u> 1394	For selecting the VTR control. LOCAL: Control from the unit only 1394: Control from 1394
SET UP	0% <u>7.5%</u>	For selecting the CAM OUT/VIDEO OUT output setup. For selecting the CAM OUT/VIDEO OUT output setup. When 7.5 % is selected, 7.5 % setup is also applied to the tape.

VTR FUNCTION

Item	Setting options	Remarks
TC MODE	<u>DF</u> NDF	For setting the time code to the DF or NDF mode. DF: Drop frame mode NDF: Non-drop frame mode
UB MODE	<u>USER</u> TIME DATE TCG	For selecting what is to be recorded in the user's bit area. USER: User setting (fixed) TIME: Real time value in hours/minutes/seconds DATE: Real time value in year/month/day/hours TCG: Time code generator value
FIRST REC TC	<u>REGEN</u> PRESET	For selecting whether the TC REGEN mode is to be established when recording is started. REGEN: The regeneration mode is established for the time code on the tape. PRESET: The regeneration mode is not established for the time code on the tape. However, it is forcibly established when the unit is transferred from REC PAUSE to REC.
BACK TALLY	<u>ON</u> OFF	For selecting whether the back tally lamp is to light. ON: The lamp lights. OFF: The lamp does not light.
FF/REW SPEED	x32 x64 <u>x100</u>	For setting the fast forward and rewind speed. x32: 32 times normal speed x64: 64 times normal speed x100: 100 times normal speed
AUDIO SAMPLING	32K <u>48K</u>	For selecting the audio sampling frequency. 32K: 32 kHz 48K: 48 kHz

VTR OPTION

Item	Setting options	Remarks
TIME STAMP	<u>REC</u> NO-REC	For selecting whether to superimpose the date and time onto the camera's video recording. REC: Superimposed NO-REC: Not superimposed
INTERVAL REC	<u>OFF</u> ON ONE-SHOT	For setting whether to perform intermittent recording. OFF: Not performed ON: Performed ONE-SHOT: Recording is performed once for the period set for REC TIME, and then stops.
REC TIME	<u>00m05s</u> : 59m59s	For setting the recording time for intermittent recording. <Note> The REC TIME setting is effective only when ON or ONE-SHOT is set for INTERVAL REC.
INTERVAL TIME	00h00m10s : 23h59m59s	For setting the REC PAUSE time during intermittent recording. <Note> The INTERVAL TIME item is valid only when ON has been selected as the INTERVAL REC setting.
PAUSE TIME	<u>10min</u> 20min 30min	For setting the time that is allowed to elapse before REC PAUSE is replaced with SAVE. 10min: 10 minutes 20min: 20 minutes 30min: 30 minutes

BATTERY

Item	Setting options	Remarks
BATTERY SELECT	<u>NiCd12</u> NiCd13 NiCd14 TYPE A TYPE B	For selecting the type of battery used. NiCd12: NP-1B made by Sony NiCd13: TRIM13 made by Anton Bauer NiCd14: TRIM14 made by Anton Bauer TYPE A: AJ-BP490 TYPE B: Digital 14V (Hitron 100) made by Anton Bauer
TYPE A NEAR END	11.0V : <u>11.6V</u> : 15.0V	For designating the type A voltage. When the voltage set here is reached, the battery is considered to have a minimal remaining charge, and a warning is displayed. A voltage from 11.0V to 15.0V is used as the setting.
TYPE A END	11.0V : <u>11.2V</u> : 15.0V	For designating the type A voltage. When the voltage set here is reached, the battery is considered to be flat, and a warning is displayed. A voltage from 11.0V to 15.0V is used as the setting.
TYPE B NEAR END	11.0V : <u>12.7V</u> : 15.0V	For designating the type B voltage. When the voltage set here is reached, the battery is considered to have a minimal remaining charge, and a warning is displayed. A voltage from 11.0V to 15.0V is used as the setting.
TYPE B END	11.0V : <u>12.4V</u> : 15.0V	For designating the type B voltage. When the voltage set here is reached, the battery is considered to be flat, and a warning is displayed. A voltage from 11.0V to 15.0V is used as the setting.

" " denotes the mode which was set at the factory.

Menu contents

MAIN menu 1 of 2 (main menu) MIC/AUDIO

Item	Setting options	Remarks
FRONT MIC POWER	ON OFF	ON: Phantom power is supplied to the front microphone. OFF: Phantom power is not supplied to the front microphone.
FRONT MIC	-40dB -50dB -60dB	For selecting the camera mic input level.
REAR MIC CH1	-40dB -50dB -60dB	For setting the input mic level for the rear jack AUDIO CH1 input.
REAR MIC CH2	-40dB -50dB -60dB	For setting the input mic level for the rear jack AUDIO CH2 input.
MIC LOWCUT CH1	ON OFF	ON: The low-cut filter is set to ON for the rear jack AUDIO CH1 mic input. OFF: The low-cut filter is set to OFF for the rear jack AUDIO CH1 mic input.
MIC LOWCUT CH2	ON OFF	ON: The low-cut filter is set to ON for the rear jack AUDIO CH2 mic input. OFF: The low-cut filter is set to OFF for the rear jack AUDIO CH2 mic input.
LINE CH1	+4dB 0dB -6dB	For selecting the rear jack AUDIO CH1 line input level.
LINE CH2	+4dB 0dB -6dB	For selecting the rear jack AUDIO CH2 line input level.

LENS SHADING

Item	Setting options	Remarks
LENS SELECT	A B C USER	For selecting the type of lens mounted on the unit. A: S18 x 6.7BERM4 S18 x 6.7BRM4 S19 x 6.5BERM4 S19 x 6.5B YH18 x 6.7IRS YH12 x 4.8IRS B: YH18 x 6.7KRS YH14 x 7.3KRS YH12 x 4.8KRS S14 x 7.5BRM4 S17 x 6.6BRM4 C: S14 x 7.3BRM (For AG-DVC200L) USER: Lens other than A, B or C
SHADING (USER)		For performing shading compensation for the USER lens.

MAIN menu 2 of 2 (main menu)

→NEXT**** MAIN 2 / 2 ****

MARKER/ZEBRA...
VF DISPLAY 1/2...
VF DISPLAY 2/2...
! LED...
GENLOCK...
CAMERA ID...
TIME/DATE...
DIAGNOSTIC...

MARKER/ZEBRA

Item	Setting options	Remarks
SAFETY ZONE	OFF 01 : 06 : 09	For selecting the shape of the safety markers. OFF: No markers are displayed. 01: 80% and 90% corner display 02: 80% corner display 03: 90% corner display 04: 80% and 90% box display 05: 80% box display 06: 90% box display 07: 16:9 picture frame and 90% of 16:9 display 08: 16:9 picture frame and 80% of 16:9 display 09: 16:9 picture frame (100%) display
CENTER MARK	ON OFF	For setting the center marker display to ON or OFF. ON: Displayed OFF: Not displayed
ZEBRA1 DETECT	070% : 104%	For setting the boundary at which the zebra 1 pattern appears.
ZEBRA2 DETECT	071% : 085% : 105%	When the next menu item, ZEBRA2, is set to SPOT or OFF: → This item sets the boundary at which the zebra 1 pattern appears. When the next menu item, ZEBRA2, is set to ON: → This item sets the boundary level at which the pattern is switched to zebra 1. <Note> The ZEBRA2 DETECT level must be set higher than the ZEBRA1 DETECT level.
ZEBRA2	ON OFF SPOT	For selecting the zebra 2 pattern type. ON: Zebra patterns 1 and 2 are displayed. OFF: Only zebra pattern 1 is displayed. SPOT: Zebra pattern 1 is displayed from the level set for ZEBRA1 DETECT to the level set for ZEBRA2 DETECT.
VF DTL	1 2 3 OFF	For selecting VF DTL. The higher the number, the more the detail of the signals for the viewfinder is emphasized. When OFF is set, the detail signals are not output.

“ _____ ” denotes the mode which was set at the factory.

Menu contents

MAIN menu 2 of 2 (main menu)

VF DISPLAY 1/2

The information to be displayed in the viewfinder is selected on this menu.

Item	Setting options	Remarks
FILTER	ON OFF	For setting the filter position display ON or OFF. ON: Displayed OFF: Not displayed
GAIN	ON OFF	For setting the gain switch position display ON or OFF. ON: Displayed OFF: Not displayed
WHITE BAL	ON OFF	For setting the WHITE BAL switch position and ATW display ON or OFF. ON: Displayed OFF: Not displayed
COLOR TEMP	ON OFF ATW ONLY	For setting the color temperature and fine color temperature adjustment amount displays ON or OFF. ON: Displayed OFF: Not displayed ATW ONLY: The color temperature is displayed only with ATW, and the fine color temperature adjustment amount is not displayed.
IRIS (F Number)	ON OFF	For setting the F-value display ON or OFF. ON: Displayed OFF: Not displayed
ZOOM	ON OFF	For setting the zoom display ON or OFF. ON: Displayed OFF: Not displayed
TCG	TCG TCR TCG/TCR OFF	For setting the time code display ON or OFF. TCG: The value set using the TC/UB/COUNTER switch is displayed in the EE mode only. TCR: The value set using the TC/UB/COUNTER switch is displayed in the VV mode only. TCG/TCR: Depending on the TC/UB/COUNTER switch setting, the TCG/UBG/COUNTER value is displayed in the EE mode, and the TCR/UBR/COUNTER value is displayed in the VV mode. OFF: Not displayed
LEVEL METER	OFF CH1 CH2 CH1+CH2	For setting the audio level meter display ON or OFF. OFF: Not displayed CH1: Only the CH1 audio level is displayed. CH2: Only the CH2 audio level is displayed. CH1+CH2: The CH1 and CH2 audio levels are displayed.
TAPE REMAIN	ON OFF	For setting the tape type and remaining tape display ON or OFF. ON: Displayed OFF: Not displayed
BATTERY	ON OFF	For setting the battery voltage display ON or OFF. ON: Displayed OFF: Not displayed

VF DISPLAY 2/2

The information to be displayed in the viewfinder is selected on this menu.

Item	Setting options	Remarks
SHUTTER SPEED	ON OFF	For setting the shutter speed display ON or OFF when the shutter is ON. ON: Displayed OFF: Not displayed
IRIS (SPOT, BACK)	ON OFF	For selecting whether SPOT or BACK is to be displayed when the auto iris selector switch is at SPOT.L or BACK.L. ON: Displayed OFF: Not displayed
AUTO/SCENE NAME	ON OFF	For setting the AUTO or SCENE FILE name display ON or OFF when FULL AUTO or SCENE FILE has been selected. ON: Displayed OFF: Not displayed
LOW LIGHT	ON OFF	For setting the LOW LIGHT display ON or OFF when shooting under low-light conditions. ON: Displayed OFF: Not displayed
TIME/DATE	TIME DATE TIME+DATE OFF	For selecting whether to display the date and time when the camera's images are output. TIME: Only the time is displayed. DATE: Only the date is displayed. TIME+DATE: The time and date are displayed. OFF: Neither the time nor date is displayed.
EXTENDER	ON OFF	For setting the EXT display ON or OFF when the extender is ON. ON: Displayed OFF: Not displayed
AUDIO SAMPLING	ON OFF	For setting the sampling frequency display ON or OFF. ON: Displayed OFF: Not displayed

“ _____ ” denotes the mode which was set at the factory.

Menu contents

MAIN menu 2 of 2 (main menu)

!LED

Whether the !LED display is to appear on the viewfinder screen is selected on this menu.

Item	Setting options	Remarks
GAIN	OFF <u>W/O 0dB</u>	For setting the !LED display ON or OFF at any gain setting except 0 dB. OFF: Not displayed W/O dB: Displayed at any gain setting except 0 dB
WHITE	ATW PRE <u>OFF</u>	For setting the !LED display ON or OFF when the WHITE BAL switch is at the PRE position or ATW has been set. ATW: Displayed in the ATW mode. PRE: Displayed when PRE is the position setting. OFF: Not displayed
SHUTTER	ON OFF	For setting the !LED display ON or OFF when the shutter is ON. ON: Displayed OFF: Not displayed
FILTER	OFF W/O No 1 No 1 <u>NG</u>	For setting the !LED display relating to the filter ON or OFF. OFF: Not displayed W/O No.1: Displayed except when filter 1 is set. No.1: Displayed when filter 1 is set. NG: Displayed when the filter position is not fixed.
EXTENDER	ON OFF	For setting the !LED display ON or OFF when the extender is ON. ON: Displayed OFF: Not displayed
SUPER V	ON <u>OFF</u>	For setting the !LED display ON or OFF when SUPER V is ON. ON: Displayed OFF: Not displayed

GENLOCK

Item	Setting options	Remarks
H PHASE	000 : <u>200</u> : 255	For finely adjusting the horizontal sync phase during gen-lock.
SC PHASE COARSE	00 : <u>07</u> : 15	For coarsely adjusting the burst phase during gen-lock.
SC PHASE FINE	000 : <u>128</u> : 255	For finely adjusting the burst phase during gen-lock.

CAMERA ID

Item	Setting options	Remarks
CAMERA ID	ID ID+ (TIME+ DATE) OFF	For displaying and recording the ID data when color bar signals are supplied. ID: The ID data is displayed and recorded. ID+(TIME+DATE): The ID data and time/date are displayed and recorded. OFF: The ID data is neither displayed nor recorded.

TIME/DATE

Item	Setting options	Remarks
YEAR	00 : <u>01</u> : 99	For setting the year.
MONTH	01 : 12	For setting the month.
DAY	01 : 31	For setting the day of the month.
HOUR	00 : 23	For setting the hour.
MINUTE	00 : 59	For setting the minutes.

DIAGNOSTIC

Item	Setting options	Remarks
OPERATION		VTR ON time (indicated in hour increments)
DRUM RUNNING		Head cylinder rotation time (indicated in hour increments)
THREADING		Number of loading/unloading times
SYSCON Ver		SYSCON software version display
CAMERA Ver		CAMERA software version display
SERVO Ver		SERVO software version display

“_____” denotes the mode which was set at the factory.

Warning system

When an error or trouble is detected immediately after the power is turned on or while an operation is underway, the WARNING lamp and lamps inside the viewfinder serve to alert the user to the occurrence of the error or trouble.

■ SLACK

WARNING lamp	Flashes four times per second.
Tally lamp	Flashes four times per second.
Viewfinder	The SLACK display flashes.
Description of warning	Trouble has occurred in the motor, solenoid or other mechanism.
VTR unit operation	The tape stops traveling. When solenoid trouble has been detected, the power is turned off.
Remedial action	Check the error code (see page 40) shown in the viewfinder and consult your nearest service center.

■ REC WARNING

WARNING lamp	Flashes four times per second (for over 3 seconds during recording).
Tally lamp	Flashes four times per second (for over 3 seconds during recording).
Viewfinder	The REC WARNING display flashes (for over 3 seconds during recording).
Description of warning	Trouble has occurred with the recording control signals.
VTR unit operation	Recording continues but it may not be performed properly while the warning is displayed.
Remedial action	This trouble has occurred with the control signals inside the unit. Consult your nearest service center.

■ RF

WARNING lamp	Flashes four times per second (during recording).
Tally lamp	Flashes four times per second (during recording).
Viewfinder	The RF display flashes (during recording).
Description of warning	The video heads are clogged. This trouble occurs in the recording system.
VTR unit operation	The cleaning roller is actuated to clean the heads (max. 3 seconds). Recording continues but it may not be performed properly. The warning display remains flashing up to the REC/PAUSE mode. It goes out when the unit's mode is transferred from REC/PAUSE.
Remedial action	Clean the heads. If recording still cannot be performed properly even after cleaning, turn off the unit's power, and consult your nearest service center.

■ SERVO

WARNING lamp	Flashes four times per second (during recording and playback).
Tally lamp	Flashes four times per second (during recording and playback).
Viewfinder	The SERVO display flashes (during recording and playback).
Description of warning	The servo is out of sync.
VTR unit operation	Operation continues but it may not be performed properly.
Remedial action	Turn off the unit's power, and consult your dealer.

■ HUMID

WARNING lamp	<ul style="list-style-type: none"> • Lights when condensation has been detected. • Flashes once a second from 10 minutes after the condensation detection has been released for a duration of 80 minutes.
Tally lamp	<ul style="list-style-type: none"> • Flashes four times per second starting at the time when the condensation was detected until 10 minutes have elapsed after the condensation detection was released. • The lamp turns off 10 minutes after the condensation detection status is released.
Viewfinder	The HUMID display flashes starting at the time when the condensation was detected until 90 minutes have elapsed after the condensation detection was released.
Description of warning	Condensation has formed.
VTR unit operation	The recording operation continues but it will stop if the tape sticks. For 80 minutes after the condensation detection was released, the operation which causes the drum to rotate is not acknowledged.
Remedial action	Stop the tape travel, and turn off the unit's power. If the HUMID display fails to go out even after the power has been turned back on, wait until it goes out.

■ TAPE NEAR END

WARNING lamp	Flashes once per second (during recording).
Tally lamp	Flashes once per second (during recording).
Viewfinder	<ul style="list-style-type: none"> • The remaining tape display flashes (in the EE mode) •  flashes for 3 seconds one minute before the tape-end.
Description of warning	The tape is approaching its end (2 minutes remain).
VTR unit operation	Operation continues.
Remedial action	Replace the cassette tape as necessary.

Warning system

■ TAPE END

WARNING lamp	Lights (during stop and standby OFF).
Tally lamp	Flashes four times per second (during stop and standby OFF).
Viewfinder	END lights, and the TAPE END display flashes (during stop and standby OFF).
Description of warning	The tape has come to the end.
VTR unit operation	If the unit is in the recording, playback or fast forward mode, operation is stopped.
Remedial action	Rewind the tape. Alternatively, replace the cassette tape.

■ BATTERY NEAR END

WARNING lamp	Flashes once per second.
Tally lamp	Flashes once per second.
Viewfinder	The BATT NEAR END display flashes.
Description of warning	The battery is nearly flat.
VTR unit operation	Operation continues.
Remedial action	Replace the battery as necessary.

■ BATTERY END

WARNING lamp	Lights.
Tally lamp	Flashes once per second.
Viewfinder	The BATT END display flashes.
Description of warning	The battery is flat.
VTR unit operation	All operations are stopped, and the tape is unloaded. Only the cassette tape eject operation is acknowledged.
Remedial action	Replace the battery.

<Note>

Given below is the sequence of priority for the WARNING lamp, tally lamp and warnings in the viewfinder. If more than one error has occurred at the same time, the display with the higher priority appears.

1. SLACK
2. BATTERY END
3. REC WARNING
4. TAPE END
5. HUMID
6. SERVO
7. RF
8. BATTERY NEAR END
9. TAPE NEAR END

Emergency eject

If the cassette cannot be ejected even when the EJECT button is pressed, the tape can still be removed by using a screwdriver to push and simultaneously rotate the EMERGENCY screw.

1 Set the power to OFF.

2 As shown in the figure, remove the rubber cap, and insert a Phillips head screwdriver into the cross-recessed part of the EMERGENCY screw (red).

1 Set the power to OFF.

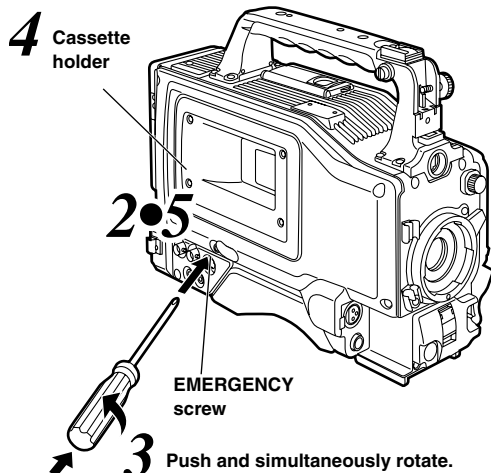

3 While pushing the screwdriver, keep turning the EMERGENCY screw counterclockwise until the tape is ejected.

- From the moment when the screw is first turned, it takes about 20 turns for unloading to commence.
- From the moment when the screw is first turned, it takes about 90 turns for the tape to be ejected.

4 Remove the cassette.

5 Return the rubber cap to its original position.

<Notes>

- Refrain from turning the EMERGENCY screw except in an emergency.
- Do not turn the screw clockwise. Do not turn the screw any more after the tape has been ejected. Doing so may damage the mechanism.
- After the tape has been ejected, the cassette holder will not lock even when it is closed. The power must be turned back on, and the mechanical operations reset before closing the cassette holder.
- When the EMERGENCY screw is turned, a clicking sound will be heard: this is the sound of the reel drive operating which is normal and not indicative of malfunctioning.

Maintenance

Condensation

When the unit is taken from cold to warm surroundings or used in a very humid place, the water vapor contained in the air may turn into droplets of water when it makes contact with the head drum. This phenomenon is known as condensation, and if the tape is run while condensation has formed inside the unit, the tape tends to stick to the head drum.

Bear in mind the following points:

- Remove the tape before starting to use the unit under conditions which may be conducive to the formation of condensation.
- Before inserting the tape, set the power switch to ON, and check that the HUMID display has not lighted in the viewfinder.

<Note>

To ensure safety, the HUMID display remains flashing and the head drum is rotated for 80 minutes after the condensation detection has been released.

During this period, none of the control buttons will operate.

Replacing the backup battery

The backup battery is mounted in the unit prior to the unit's shipment from the plant.

When the backup battery is used up and the power switch is set to ON, the BACKUP BATTERY EMPTY message appears in the viewfinder for 5 seconds.

After consulting your dealer, replace the old backup battery with a new one (CR2032 or BR2032). After replacing the battery, press the backup battery cover firmly into place until a click is heard. For details on the battery position, refer to "Parts and their functions" (pages 6 and 7).

Error codes

When an error has occurred in the unit for some reason or other, one of the error codes shown on the right will be displayed in the viewfinder.

Cleaning the heads

Use the AY-DVCL cleaning cassette when it is necessary to clean the heads.

Since the video heads may be damaged if the proper directions for using cleaning cassette are not followed, read the handling instructions which accompany the cleaning tape prior to use.

Cleaning inside the viewfinder

- Do not use paint thinners or other solvents to remove dirt.
- Use a lens cleaner available on the market to wipe the lens.
- Never wipe the mirror under any circumstances.
If dirt or dust has adhered to the mirror, blow it away using an air blower available on the market.

Concerning phenomena inherent to CCD cameras

Smear

This may occur when extremely bright subjects are shot. The higher the electronic shutter speed, the more this phenomenon is liable to occur.

Code No.	Description
04	Pinch solenoid trouble
08	Cleaning solenoid trouble
0B	Supply reel trouble
0C	Take-up reel trouble
0D	Capstan trouble
0E	Head cylinder trouble
0F	Loading trouble

Specifications

[GENERAL]

Power requirements: DC 12V (11.0V to 17.0V) Power consumption: 17W

 indicates safety information.

Operating temperature:	0 to 40 C
Storage temperature:	-20 to +60 C
Operating humidity:	Less than 85% (relative humidity)
Continuous operating time:	Approx. 120 min. (continuous recording time using the TRIMPAC14 made by Anton Bauer)
Dimensions:	123(W) x 190(H) x 292(D) mm (excluding grip)
Weight:	Approx. 3 kg (main unit only)

[CAMERA UNIT]

Pickup device:	1/2-inch IT type CCD (410,000 pixels)
System:	RGB 3-CCD system
Total number of pixels:	811(H) x 508(V)
Number of effective pixels:	768(H) x 494(V)
Spectral system:	f/1.4 prism system
Internal filters:	1: 3200K (clear) 2: 5600K + 1/8N 3: 5600K 4: 5600K + 1/64ND
Quantizing:	10 bits, non-linear
Sampling frequency:	14.31818 MHz (4 fsc)
Digital signal processing:	28.63636 MHz (8 fsc)
Horizontal drive frequency:	28.63636 MHz (8 fsc)
Programmable gain:	3 positions (L, M and H) selected from 0, 3, 6, 9, 12, 15, 18, 21, 24, 30, 36 dB
Shutter speed	Preset: 1/100, 1/120, 1/250, 1/500, 1/1000, 1/2000 Variable: 1/60.3 to 1/250.0
Lens mount:	Bayonet type
Sensitivity:	f/11 (2000 lux)
Minimum subject brightness:	0.5 lux (at f/1.4 + 36 dB)
Video S/N ratio:	62 dB (standard)
Horizontal resolution:	Over 800 lines (at center) (CAM OUT connector)
Registration:	Less than 0.05% (total area, lens distortion excluded)
Geometric distortion:	Negligible (lens distortion excluded)

Specifications

[VTR UNIT]

Video system

Recording format:	DV format
Sampling frequency	Y: 13.5 MHz PB/PR: 3.375 MHz
Quantizing:	8 bits

Audio system

Recording format:	Digital PCM stereo recording 16 bits (48 kHz/2 channels) 12 bits (32 kHz/2 channels)
Frequency response:	20 Hz to 20 kHz (at 48 kHz)

Tape transport system

Tape format:	DV standard cassettes
Tape speed:	18.812 mm/sec.
Maximum recording time:	270 min.

[CONNECTOR SECTION]

Input

AUDIO IN CH1/CH2 (XLR x 2, 3 pins):	LINE/MIC/MIC+48V switching system MIC: -40, -50, -60 dBu menu-selectable LINE: -6, 0, +4 dBu menu-selectable MIC+48V: Phantom +48V supported
MIC IN (XLR x 2, 3 pins):	MIC/MIC+48V switching system MIC: -40, -50, -60 dBu menu-selectable MIC+48V: Phantom +48V supported (menu-selectable)
GEN LOCK IN (BNC):	1.0 V _{P-P} , 75 Ω

Output

CAMERA OUT (BNC):	1.0 V _{P-P} , 75 Ω
VIDEO OUT (BNC):	1.0 V _{P-P} , 75 Ω
S-VIDEO OUT (S connector)	Y signal: 1.0 V _{P-P} , 75 Ω C signal: 0.286 V _{P-P} , 75 Ω
AUDIO OUT CH1/CH2 (RCA x 2):	-6 dBu, low impedance, unbalanced
PHONE OUT (stereo mini jack):	-30 to -80 dBu

Other

DV 1394 (4 pins):	IEEE1394 input/output
DC IN (XLR, 4 pins, male):	DC 12V (DC 11 to 17V)
DC OUT (4 pins):	DC 12V (DC 11 to 17V), max. 1A (DC 7V, max. 1A output also available)

LENS (multi-connector, 12 pins)

EVF (multi-connector, 20 pins)

Specifications

[VIEWFINDER]

(Optional accessory AJ-VF10P)

CRT:	1.5-inch high-resolution monochrome CRT
Video system:	525i/59.94 Hz
External controls	Controls: BRIGHT, CONTRAST, PEAKING Switches: TALLY HIGH/OFF/LOW, ZEBRA ON/ OFF

[ACCESSORIES]

- Battery holder (already installed on unit) for Anton Bauer products
- Microphone
- Tripod plate

[RELATED EQUIPMENT]

Power supply-related products

Battery packs:	AU-BP402, AJ-BP490
Battery chargers:	AJ-B425 (for charging the AU-BP402 battery pack) AJ-B450 (for charging the AU-BP402 and the AU-BP490 battery pack)
Battery case:	AU-M402H
AC adapter:	AJ-B75

Audio products

Microphone kit:	AJ-MC700P
Microphone holder:	AJ-MH700P
Wireless mic receiver:	WX-RJ700
Camera attachment:	WX-ZJ770

Maintenance products

Cleaning tape:	AY-DVCL
Soft carrying case:	AJ-SC900
Rain cover:	SHAN-RC700
Shoulder strap:	VFC2588 (service part)

Panasonic

PANASONIC BROADCAST & TELEVISION SYSTEMS COMPANY
DIVISION OF MATSUSHITA ELECTRIC CORPORATION OF AMERICA

Executive Office:

3330 Cahuenga Blvd W., Los Angeles, CA 90068 (323) 436-3500

EASTERN ZONE:

One Panasonic Way 4E-7, Secaucus, NJ 07094 (201) 348-7621

Southeast Region:

1225 Northbrook Parkway, Ste 1-160, Suwanee, GA 30024 (770) 338-6835

Central Region:

1707 N Randall Road E1-C-1, Elgin, IL 60123 (847) 468-5200

WESTERN ZONE:

3330 Cahuenga Blvd W., Los Angeles, CA 90068 (323) 436-3500

Government Marketing Department:

52 West Gude Drive, Rockville, MD 20850 (301) 738-3840

Broadcast PARTS INFORMATION & ORDERING:

9:00 a.m. – 5:00 p.m. (EST) (800) 334-4881/24 Hr. Fax (800) 334-4880

Emergency after hour parts orders (800) 334-4881

TECHNICAL SUPPORT:

Emergency 24 Hour Service (800) 222-0741

Panasonic Canada Inc.

5770 Ambler Drive, Mississauga, Ontario L4W 2T3 (905) 624-5010

Panasonic de Mexico S.A. de C.V.

Av angel Urraza Num. 1209 Col. de Valle 03100 Mexico, D.F. (52) 1 951 2127

Panasonic Sales Company

Division of Matsushita Electric of Puerto Rico Inc.

San Gabriel Industrial Park, 65th Infantry Ave., Km. 9.5, Carolina, Puerto Rico 00630 (787) 750-4300